



Cleco® Pneumatic Assembly Tools

COOPER PowerTools



ISO-9001	2
Warranty, Lubrication, Safety	3
Model Number Index	5
Screwdrivers	8
Introduction	8
Clutch Selection Guide	9
Inline – Clutch	10
Pistol – Clutch	12
Pistol – Stall	16
Nomenclature	17
Accessories	18
Balance Arms	21
Introduction	21
Accessories	24
Angle Nutrunners	25
Introduction	25
Angle Nutrunners – Clutch	28
Angle Nutrunners – Stall	32
Reaction Bar & Swingbar Nutrunners	34
Introduction	34
Inline & Pistol Tools	36
Specialty Tools	38
Flush Socket Nutrunners	38
Crowfoot Nutrunners	40
Hold & Drive Nutrunners	42
Tube Nut Wrenches	44
Nutrunner Accessories	46
General	46
Torque Verifier	47
Ratchet Wrenches	50
Introduction	50
Accessories	55
Pulse Nutrunners	58
Introduction	58
Accessories	62
Impact Wrenches	64
Introduction	64
Impact Wrenches	66
General Accessories	68
Balancers	68
Apex Fastener Tools	70
General Information	74
Conversion Tables	74
Service & Training	76
Sales & Service Centers	78
Cooper Power Tools on the Web	79
On-Line Catalogs	80

Cooper Power Tools Division has attained ISO 9001 Quality System Certification for seven of our facilities. The driving force behind the implementation of the Quality System is the commitment "to provide our customers with the **best value delivered** by offering only products and services **that meet or exceed their expectations**".



Lexington, South Carolina



Dayton, Ohio



Hicksville, Ohio



Springfield, Ohio



Braunschweig, Germany



Westhausen, Germany



Ozoir-la-Ferrière, France

Warranty

Cooper warrants products and parts sold by it, insofar as they are of its own manufacture, against defects of material and workmanship, under normal use and service in accordance with its written instructions, recommendations, and ratings for installation, operation, maintenance, and service of products, for a period of **ONE YEAR FROM THE DATE OF INITIAL USE, BUT IN NO EVENT SHALL THE WARRANTY EXCEED 24 MONTHS FROM DATE OF DELIVERY TO DISTRIBUTOR.** Proof of Purchase with shipment date must be furnished by the user to validate the warranty. This warranty applies only to products manufactured by Cooper and specifically excludes products manufactured by others. Products not manufactured by Cooper are warranted only to the extent and in the manner warranted to Cooper by the manufacturer

and then only to the extent Cooper is able to enforce such warranty. Cooper's warranty with respect to products manufactured by it is limited to the repair or replacement, as Cooper may elect, of any defective part regarding which the Distributor has given 5 days written notice from the discovery of such defect. Installation and transportation costs are not included. Cooper shall have the option of requiring the return to it of the defective material, transportation prepaid, for inspection. No allowance will be made for repairs without Cooper's approval. **COOPER MAKES NO OTHER WARRANTY OF ANY KIND WHATSOEVER, EXPRESSED OR IMPLIED, AND HEREBY DISCLAIMS ALL WARRANTIES OF MERCHANTABILITY AND FITNESS FOR A PARTICULAR PURPOSE.**

Lubrication Products

Cooper Power Tools' products are classified as non-hazardous manufactured items, defined in the OSHA 1910.1200 Hazard Communication Standard as "Articles". These products, under conditions of normal use, do not release or cause exposure to a hazardous chemical.

Under normal conditions of use, lubrication products sold separately for or used within these tools should not cause an exposure hazard. Refer to the Material Safety Data Sheet (M.S.D.S.) for Safety and Disposal Information. M.S.D.S. sheets are available upon request from Cooper Power Tools.

Cooper is also aware of, and complies with, the

provisions of section 611 amendments to the Clean Air Act of 1990. No ozone depleting chemicals have been used in the manufacture of our products.

If you resell or distribute these products, you have the responsibility for ensuring that the Material Safety Data Sheets are provided to the purchaser.

Proper lubrication is essential to the economical operation of pneumatic and electric tools. Cooper Power Tools perform better and their life is extended by using the recommended lubricants. All lubricants that are listed in the accessory section of this catalog have undergone extensive testing and are recommended for use with Cooper Power Tools products.

Fastener Selection

The suggested fasteners listed in this catalog are determined by matching a tool's maximum rated load to Society of Automotive Engineers (SAE) Grade 5 and International Organization of Standardization (ISO) Grade 9.8 fasteners. The torque capabilities for SAE Grade 5 fasteners are from SAE Manual, SAE J429 (Mechanical and Material Requirement for Externally Threaded Fasteners). The torque capabilities for ISO Grade 9.8 fasteners are from ISO 898-1 (Mechanical Properties of Fasteners). All values selected are based on lubricated fasteners.

The suggested fasteners listed in this catalog are advisory only, and Cooper Power Tools recommends that you further consult other technical references before final tool selection. Reliance on the accuracy of this catalog data for any purpose by anyone is at the sole risk of that person. Cooper Power Tools is not responsible for any loss, claim, or damage arising from improper tool selection.

The torque values listed under the headings "TORQUE" are tested on an ISO 5393 soft joint rate test fixture unless otherwise stated by a special note.

Pneumatic Assembly Tool Safety

General Safety Instructions

These Safety Instructions must be accessible to the operator at all times. They must be shown and made available to all people involved in the use of the tool.



The operator must understand the Safety Instructions and the Installation, Operation, and Adjustment Procedures provided in the Technical Manual (included with the tool). These Safety Instructions are not intended to be all inclusive. Study and comply with all applicable Federal, State, and Local Regulations. Contact your local distributor for assistance.



This symbol identifies the potential for a hazardous situation. If this warning is not followed, a serious injury could occur.



Always disconnect the tool from the air hose before adjusting or repairing.



Immediately shut off the tool in the case of unusual sound or vibration. Disconnect the tool from the air hose. Have a qualified person check the tool and repair before using.

When unpacking the tool, closely check for shipping damages and accuracy of the shipping documentation.



Do not wear loose clothing, jewelry, or rings. Injury may result from being caught in tools. Avoid direct contact with lubricants, grease or adhesives.



Safety glasses or face shield must be worn.



Wear gloves, ear protection and other protective equipment when required.

Do not modify the tool, any guard or accessory unless approved in writing by Cooper Power Tools.



We recommend the use of a reaction bar to prevent an uncontrollable reaction of the tool. This use is dependant on the following factors: torque, joint, air pressure, form of the tool and the individual user. Consider the use of reaction bars to prevent possible injury.

Implement and follow a Safety Maintenance Program to provide inspection and maintenance of all phases of tool operation and air supply equipment.



Sockets and bits used with nutrunners and screwdrivers should be of the power tool or industrial type. Do not use hand tool sockets on a power tool. Hand tool sockets can break, resulting in a hazard of flying pieces. Worn sockets or bits reduce the power delivered to the fastener, cause drive wear and increase the chance for breakage. Inspect sockets, bits and drives for wear or damage and replace as necessary.

Noise & Vibration

Refer to test data page included with tool.

Intended Use

Air assembly tools are intended for tightening of threaded joints only. Tools must be used for their designated purpose. Do not use as a hammer, lever or other improper usage that can cause tool damage and lead to operator injury.

Installation & Operation

Only qualified and trained operators should install, adjust or use air assembly tools.

Connect the tool to an air line with a maximum pressure of 6.2 bar (90 psig). Adjust the air line lubrication to a minimum to reduce possible contamination of the environment by the exhaust air. The work area must be well ventilated.



Inspect the air hose and fittings. Do not use damaged, frayed or deteriorated hoses. A hose rupture can cause injury.



When using right angle nutrunners, be sure the throttle is positioned relative to the angle head so the throttle will not become wedged against an adjacent object in the ON position due to torque reaction.

The angle head may be repositioned with respect to the lever to accommodate proper location for the task. If the tool is to be reversed, locate throttle lever in a neutral position that will prevent entrapment.

Keep the tool clean and dry to provide the best possible grip. The tool should be held in such a way to be safe and comfortable. Firmly grasp the handle of the tool and apply the socket to the joint before starting the tool.

Adjusting Torque For Shut-Off Tools



Screwdrivers and nutrunners with clutches can stall rather than shut off if the clutch is adjusted over the maximum power output of the tool, or if there is a drop in the air pressure. Low or fluctuating air pressure can cause tool to fail to shut off! The user must be prepared to resist the torque until the throttle is released.

Expose clutch through movement of the clutch shield. Using the hex wrench supplied, turn clockwise for maximum torque or turn counterclockwise for minimum torque.

NOTE: For best results, start from "MIN" torque and adjust in "MAX" direction.

Maintenance, Assembly & Disassembly

Inspect air assembly tools every 500 operating hours or every six months, whichever comes first. Replace worn parts using only genuine Cooper Power Tools replacement parts.

Model Number Index

Model	Page	Model	Page	Model	Page	Model	Page
200427	68	14RAA03AM2	29	14TTA02Q	13	24RAA19AM3	29
200428	68	14RAA04AM2	29	14TTA03Q	13	24RAA23AM3	29
200429	68	14RAA05AM2	29	14TTA04Q	13	24RAS13AM3	33
105PH554	61	14RAA06AH2	29	14TTA05Q	13	24RTA12	44
105PH55Q	61	14RAA06AH3	29	14TTA06Q	13	24RTA20T2	44
110PTHD55Q	61	14RAA07AH2	29	14TTA07Q	13	24RTA30T3	44
11PHL802	61	14RAA07AH3	29	14TTA10Q	13	24RTA40T4	44
11PHL80Q	61	14RAA09AH2	29	14TTA15Q	13	250PHF406	61
11PTHD652	61	14RAA09AH3	29	14TTS02Q	16	250PTHFC226	61
11PTHD653	61	14RAA11AH2	29	14TTS03Q	16	2RSA-10B	11
11PTHD65Q	61	14RAA11AH3	29	14TTS04Q	16	2RSA-10SB	11
120PTHD554	61	14RAA12AH2	29	14TTS05Q	16	30PHL70Q	61
140PH45Q	61	14RAA12AH3	29	15STHC40Q	61	34NRS29H15	53
140PTHC25Q	61	14RAS03AM2	33	15STHFC40Q	61	34NRS31H16	53
14BPA02Q	11	14RAS04AH2	33	160PH456	61	34NRS35H20	53
14BPA03Q	11	14RAS05AM2	33	160PTHC256	61	34NRS36H15	53
14BPA04Q	11	14RAS06AH3	33	20PHL703	61	34NRS36H18	53
14BPA05Q	11	14SCA02B	11	20PHL70Q	61	34NRS38H16	53
14BPA06Q	11	14SCA02Q	11	20PTHD753	61	34NRS42H25	53
14PCA02Q	13	14SCA03B	11	20PTHD75Q	61	34NRS46H18	53
14PCA03Q	13	14SCA03Q	11	24NRS15A12	53	34NRS46H20	53
14PCA04Q	13	14SCA04B	11	24NRS15A13	53	34NRS48H29	53
14PCA05Q	13	14SCA04Q	11	24NRS20H15	53	34NRS52H25	53
14PCA06Q	13	14SCA05B	11	24NRS21H16	53	34NRS53H37	53
14PTA02Q	13	14SCA05Q	11	24NRS23A13	53	34NRS63H29	53
14PTA03Q	13	14SCA06B	11	24NRS23H15	53	34NRS68H37	53
14PTA04Q	13	14SCA06Q	11	24NRS23H20	53	34RAA08AL3	29
14PTA05Q	13	14SPA02B	11	24NRS24A12	53	34RAA09F1	38
14PTA06Q	13	14SPA02Q	11	24NRS24H16	53	34RAA11AL3	29
14PTA07Q	13	14SPA03B	11	24NRS24H18	53	34RAA15AM3	29
14PTA10Q	13	14SPA03Q	11	24NRS29H18	53	34RAA16F1	38
14PTA15Q	13	14SPA04B	11	24NRS29H25	53	34RAA26AH3	29
14PTS02Q	16	14SPA04Q	11	24NRS30H20	53	34RAA28AH3	29
14PTS03Q	16	14SPA05B	11	24NRS33H29	53	34RAA28F1	38
14PTS04Q	16	14SPA05Q	11	24NRS34H25	53	34RAA33AX3	29
14PTS05Q	16	14SPA06B	11	24NRS39H37	53	34RAA33F2	38
14RAA02AH2	29	14SPA06Q	11	24NRS43H29	53	34RAA37AX3	29
14RAA02AH3	29	14TCA02Q	13	24NRS52H37	53	34RAA47AX3	29
14RAA02AM2	29	14TCA03Q	13	24RAA06AL3	29	34RAA47F2	38
14RAA03AH2	29	14TCA04Q	13	24RAA07AL3	29	34RAA53F2	38
14RAA03AH3	29	14TCA05Q	13	24RAA11AL3	29	34RAA53H3	42
14RAA03AL2	29	14TCA06Q	13	24RAA12AM3	29	34RAA67F3	38

Model Number Index

Model	Page	Model	Page	Model	Page	Model	Page
34RAA67H3	42	35RSATP-10Q	15	55NL-2T-4	33	64TTK90D4	37
34RAA68AZ3	29	35RSATP-20Q	15	55NL-3T-4	33	64TTK930D8	37
34RAA68AZ4	29	35RSATP-5-3	15	55PHL604	61	64TTS110D4	37
34RAA75AZ3	29	35RSATP-5Q	15	55PHL60Q	61	64TTS125D4	37
34RAA75AZ4	29	35RSATP-7Q	15	55PTHD603	61	64TTS1260D8	37
34RAA94F3	38	35STHFA404	61	55RNAL-2-4	37	64TTS140D4	37
34RAA94H3	42	35STHFA40Q	61	55RNAL-2T-4	31	64TTS1475D8	37
34RAS103F3	38	35STHFC404	61	55RNAL-3-4	37	64TTS150D6	37
34RAS103H3	42	35STHFC40Q	61	55RNAL-3P-4	31	64TTS175D6	37
34RAS10F1	38	400PHF356	61	55RNAL-3T-4	31	64TTS1820D8	37
34RAS11AL3	33	400PTHFC206	61	55RNAL-4-4	37	64TTS1985D8	37
34RAS18F1	38	41NDR130H15	54	55RNAL-4P-4	31	64TTS205D6	37
34RAS28AH3	33	41NDR130H16	54	55RNAL-4T-4	31	64TTS255D6	37
34RAS30F1	38	41NDR130H18	54	55RNAL-6T-4	31	64TTS345D6	37
34RAS36AX3	33	41NDR130H20	54	55RNL-2T-4	33	64TTS34D4	37
34RAS40F2	38	41NDR130H25	54	55RNL-3T-4	33	64TTS3850D12	37
34RAS52F2	38	41NDR172H15	54	55RNL-7T-4	33	64TTS425D6	37
34RAS58F3	38	41NDR172H16	54	60NDR092HD24	54	64TTS44D4	37
34RAS58H3	42	41NDR172H20	54	60NDR092HD40	54	64TTS55D4	37
34RAS73F3	38	41NDR172H25	54	60NDR092HD48	54	64TTS570D6	37
34RAS73H3	42	41NDR236H15	54	60NDR092HD56	54	64TTS640D8	37
34RCA30D1	40	41NDR236H16	54	64TTK110D4	37	64TTS750D8	37
34RCA30D3	40	41NDR236H18	54	64TTK125D4	37	64TTS75D4	37
34RCS29D1	40	45NAB-3P-4	31	64TTK1260D8	37	64TTS90D4	37
34RCS29D3	40	45RNAB-2-4	37	64TTK140D4	37	64TTS930D8	37
35PHL703	61	45RNAB-2P-4	31	64TTK1475D8	37	75NAL-2V-4	31
35PTHD653	61	45RNAB-2T-4	31	64TTK150D6	37	75NAL-2X-6	31
35PTHD65Q	61	45RNAB-3-3	37	64TTK175D6	37	75NL-2V-4	33
35RSA-10-3	11	45RNAB-3P-4	31	64TTK1820D8	37	75NL-2X-6	33
35RSA-10Q	11	45RNAB-3T-4	31	64TTK1985D8	37	75NL-3V-4	33
35RSA-20Q	11	45RNAB-4-3	37	64TTK205D6	37	75PHL504	61
35RSA-5-3	11	45RNAB-4T-4	31	64TTK255D6	37	75PHL50Q	61
35RSA-5Q	11	45RNAB-6-3	37	64TTK345D6	37	75RNAL-2V-4	31
35RSA-7Q	11	45RNB-2T-4	33	64TTK34D4	37	75RNAL-2X-6	31
35RSAP-10Q	15	45RNB-3P-4	33	64TTK3850D12	37	75RNAL-3V-4	31
35RSAP-20Q	15	45RNB-3T-4	33	64TTK425D6	37	75RNAL-3X-6	31
35RSAP-7Q	15	45RNB-4T-4	33	64TTK44D4	37	75RNL-2X-6	33
35RSAPT-10Q	15	55NAL-2T-4	31	64TTK55D4	37	75RNL-3V-4	33
35RSAPT-20Q	15	55NAL-3P-4	31	64TTK570D6	37	75RNL-3X-6	33
35RSAPT-5Q	15	55NAL-3T-4	31	64TTK640D8	37	7PHL90Q	61
35RSAPT-7Q	15	55NAL-4P-4	31	64TTK750D8	37	7STHFA55Q	61
35RSATP-10-3	15	55NAL-4T-4	31	64TTK75D4	37	7STHFC55Q	61

Model	Page	Model	Page	Model	Page	Model	Page
80PTHD604	61	8RSAPT-10BQ	15	H30NDR08H18	54	WP-455-4R	67
80PTHD60Q	61	8RSAPT-20BQ	15	H30NDR08H20	54	WPS-2109B	67
88RSA-5C-3	11	8RSAPT-40BQ	15	H30NDR08H25	54	WT-2109-8	67
88RSA-5CQ	11	8RSAPT-5BQ	15	PBA-12	23	WT-2109-8	67
88RSA-7C-3	11	8RSAPT-7BQ	15	PBA-12-AH	23	WT-2110-8	67
88RSA-7CQ	11	8RSATP-10BQ	15	PBA-12-WM	23	WT-2110-8	67
88RSAL-5C-3	11	8RSATP-20BQ	15	PBA-18	23	WT-2119-12	67
88RSAL-5CQ	11	8RSATP-30BQ	15	PBA-18-18-AH	23	WT-2119-12	67
88RSAPT-2CQ	15	8RSATP-5BQ	15	PBA-18-AH	23	WT-2120-12	67
88RSAPT-5C-3	15	8RSATP-7BQ	15	PBA-24	23	WT-2120-12	67
88RSAPT-5CQ	15	8SA-10	11	PBA-24-AH	23	WTS-2109	67
88RSAPT-7CQ	15	8SA-10BQ	11	PBA-30-AH	23	WTS-2109	67
88RSATP-2C-3	15	8SA-20BQ	11	PL-12A	68	WTS-2119	67
88RSATP-2CQ	15	8SA-7BQ	11	SBA-12	23	WTS-2119	67
88RSATP-5C-3	15	BL-2A	68	SBA-12-AH	23	WTS-2120	67
88RSATP-5CQ	15	BL-4A	68	SBA-18	23	WTS-2120	67
88RSATP-7C-3	15	BL-6A	68	SBA-18-AH	23		
88RSATP-7CQ	15	BL-8A	68	SBA-24-AH	23		
88SA-5C-3	11	BLL-6A	68	SBA-30-AH	23		
88SA-5CQ	11	BLL-8A	68	SBA-30-WM	23		
88SA-7CQ	11	BM-13A	68	TVP-110-15-D	48		
8RNO-10BQ	16	BM-18A	68	TVP-110-15-P	48		
8RNO-20BQ	16	BM-25A	68	TVP-110-15-S	48		
8RNO-7BQ	16	BM-35A	68	TVP-110-15-U	48		
8RNP-10BQ	16	BM-45A	68	TVP-110-30-D	48		
8RNP-20BQ	16	BML-13A	68	TVP-110-30-P	48		
8RSA-10	11	CPBA-12-AH	23	TVP-110-30-S	48		
8RSA-10BQ	11	CPBA-18	23	TVP-110-30-U	48		
8RSA-20	11	CPBA-18-AH	23	WL-200-3	67		
8RSA-20BQ	11	CPBA-30	23	WL-200-4	67		
8RSA-30	11	CPBA-30-AH	23	WL-200-BQ	67		
8RSA-30BQ	11	CPBA-30-WM	23	WP-2049-6	67		
8RSA-40	11	CSBA-12-AH	23	WP-2050-6	67		
8RSA-40BQ	11	CSBA18	23	WP-2059-6	67		
8RSA-5BQ	11	CSBA-18-AH	23	WP-2059-8	67		
8RSA-7BQ	11	CSBA-24	23	WP-2059-8-6E	67		
8RSAL-10BQ	11	CSBA-30	23	WP-2060B-6	67		
8RSAL-20	11	CSBA-30-AH	23	WP-2060B-8	67		
8RSAL-20BQ	11	H16NDR09H15	54	WP-2109B-8	67		
8RSAP-10BQ	15	H16NDR09H20	54	WP-2110B-8	67		
8RSAP-20BQ	15	H30NDR08H15	54	WP-255-3P	67		
8RSAP-7BQ	15	H30NDR08H16	54	WP-455-4P	67		

Cleco®

A tradition of quality is built into every screwdriver.

Cleco screwdrivers have long been recognized as the assembly tool standard against which all other brands are measured. With over 100 years of precision manufacturing experience built into each tool, Cleco screwdrivers provide users the ultimate in light and medium duty assembly tool performance.

Cleco's long standing tradition of service to the customer has led us to develop an extensive line of screwdrivers with configurations to suit a broad range of applications. Options including multiple reversing methods, different clutch styles, numerous handle alternatives, and a wide variety of accessories provide the building blocks for tool configurations designed to meet our customers' unique assembly application requirements.

The Cleco 2 series of inline Clecomatic screwdrivers offer dependable repetitive torque accuracy from .5 to 8 in.-lbs., ideal for miniature assemblies often found in extra light-duty electronics assembly using #0 to #5 screws.

In the light to medium duty assembly tool market, the ergonomically designed Cleco 14 series screwdrivers, with a torque range of 1.7 to 130 in.-lbs., are the ultimate tools for an infinite range of applications including computer, electronics, and appliance assembly.

With a torque range of 15 to 180 in.-lbs (1.7 to

60 MONTH WARRANTY

Cleco® 14 & 8 Series Clecomatic® Screwdrivers

Cooper Power Tools warrants the 14 and 8 series Clecomatic screwdrivers and parts to be free from defects in workmanship and material of the life of the tool. The clutch assemblies are warranted for SIXTY MONTHS against failure or wear causing malfunction.

Cooper Power Tools' obligation under this warranty is to repair or replace, without charge to the original purchaser, any part which does not meet the warranty outlined above during the active commercial production of this tool. This tool is to be returned to the factory with carrying charges prepaid.

This warranty shall not apply to any product that has been fixture mounted or subjected to misuse, negligence or accident; or in which parts not made or supplied by Cooper Power Tools shall have been used; or which shall have been altered or repaired by other than Cooper Power Tools personnel in a manner which in the determination of Cooper Power Tools shall have affected its operation.

THIS WARRANTY CONSTITUTES THE ENTIRE OBLIGATION OF THE COMPANY RELATING TO THE SALE AND USE OF SUCH PRODUCT AND ITS MAXIMUM LIABILITY IS LIMITED TO THE PURCHASE PRICE OF SUCH PRODUCT. IN NO EVENT SHALL THE COMPANY BE LIABLE FOR CONSEQUENTIAL, INDIRECT, INCIDENTAL OR SPECIAL DAMAGES OF ANY NATURE ARISING FROM THE SALE OF USE OF SUCH PRODUCT.

20Nm), the 8 & 88 series Cleco screwdrivers cover the gamut of medium duty assembly applications ranging from lawn and garden equipment to small recreational vehicles, and even automotive.

Capable of running down fasteners as large as 5/16 (M6), the Cleco 35 series screwdrivers are the true workhorses of the medium to heavy-duty screw assembly market.

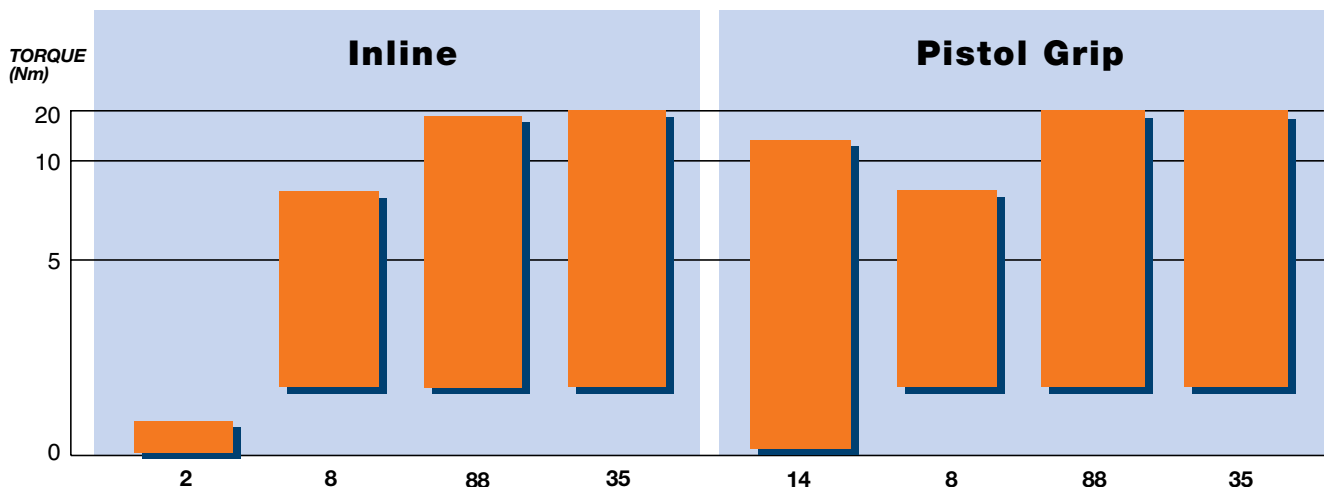



Choose the right tool to match your application.

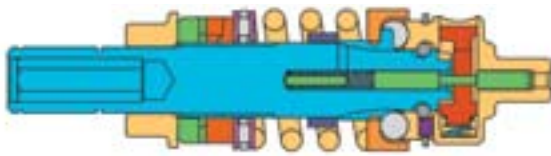

Clecomatic® Clutch

Clecomatic® Clutch

When tightening a fastener, torque is transmitted through the Clecomatic clutch to the fastener until the clutch can no longer transmit the increasing torque. The clutch then “slips”, which allows an internal mechanism to seal off air to the air motor, shutting off the tool at the user-adjusted preset torque level. This type of torque control allows maximum RPM from the tool for increased productivity. Since the tool doesn't dwell on the fastener as with a stall tool, tool wear and fatigue to the operator is reduced. The life of a Clecomatic tool is up to five times longer than that of a lever-operated, ratcheting clutch screwdriver.



Stall Type

Stall Type

The stall tool doesn't use a clutch but rather the output spindle is coupled to the last stage of gearing. Torque output from a stall tool may be controlled within fairly reasonable limits with an air pressure regulator. Stall type tools are also trigger activated.

CLUTCH SELECTION GUIDE FOR COMMON FASTENING APPLICATIONS

CLUTCH TYPE	APPLICATION				
	STANDARD BOLT & NUT	SHEET METAL SCREW	STANDARD BOLT & NUT	SELF-TAPPING SCREW	SELF-LOCKING NUT
Clecomatic®	EXCELLENT	EXCELLENT	EXCELLENT	EXCELLENT Where seating torque exceeds tapping torque	EXCELLENT
Stall Drive	FAIR Under certain conditions	GOOD Under certain conditions	FAIR Under certain conditions	FAIR Under certain conditions	FAIR

Inline Screwdrivers

2, 14, 8, 88, 35 Series Clecomatic Clutch

Cleco®

2 Series

Torque Range: .06 - .9 Nm 0.5 - 8 In. Lbs.

- Push-to-start
- Push button reverse
- External torque adjustment
- 1/4" quick change chuck

14 Series

Torque Range: .5 - 5.1 Nm 4 - 45 In. Lbs.

- Push-to-start and Push & Lever start
- External torque adjustment
- Bit & Finder & 1/4" quick change chuck

8 Series

Torque Range: 1.7 - 8.5 Nm 15.0 - 75 In. Lbs.

- Push button reverse and non-reversible
- Push-to-start and Push & Lever start
- Bit & Finder and Quick change

88 Series

Torque Range: 1.7 - 19 Nm 15 - 170 In. Lbs.

- Push button reverse and non-reversible
- Push-to-start and Push & Lever start
- Quick change & 3/8" square drive

35 Series

Torque Range: 1.7 - 20 Nm 15 - 180 In. Lbs.

- Quick change and square drive
- Short stroke button reverse
- External torque adjustment (Quick change models)



Model Number		Torque Range		Free Speed RPM	Length*		Weight		Air Consumption		
Bit & Finder*	1/4" Quick Change	in.-lbs.	Nm		in.	mm	lbs.	kg	Air Inlet NPT	Min. Hose I.D.	SCFM
Push-to-Start - Push Button Reverse											
	2RSA-10B	0.5 - 8	.06 - 0.9	1000	7.60	194	0.5	0.20	1/8"	3/16"	6
	2RSA-10SB**	0.5 - 8	.06 - 0.9	1000	6.40	162	0.5	0.20	1/8"	3/16"	6
	14BPA02Q	4 - 14	0.5 - 1.6	2300	9.05	230	1.4	0.63	1/8"	3/16"	11
	14BPA03Q	4 - 19	0.5 - 2.1	1600	9.25	235	1.4	0.64	1/8"	3/16"	11
	14BPA04Q	3 - 33	0.3 - 3.7	920	9.05	230	1.3	0.61	1/8"	3/16"	11
	14BPA05Q	2 - 45	0.2 - 5.1	560	9.45	240	1.5	0.67	1/8"	3/16"	11
	14BPA06Q	2 - 45	0.2 - 5.1	220	9.45	240	1.5	0.68	1/8"	3/16"	11
Push-to-Start - Collar Reverse											
14SPA02B	14SPA02Q	4 - 19	0.5 - 2.1	2800	9.05	230	1.4	0.63	1/8"	3/16"	11
14SPA03B	14SPA03Q	4 - 26	0.5 - 2.9	1900	9.25	235	1.4	0.64	1/8"	3/16"	11
14SPA04B	14SPA04Q	3 - 40	0.4 - 4.5	1100	9.05	230	1.3	0.61	1/8"	3/16"	11
14SPA05B	14SPA05Q	2 - 45	0.2 - 5.1	660	9.45	240	1.5	0.67	1/8"	3/16"	11
14SPA06B	14SPA06Q	2 - 45	0.2 - 5.1	260	9.45	240	1.5	0.68	1/8"	3/16"	11
Lever Push-to-Start - Collar Reverse											
14SCA02B	14SCA02Q	4 - 19	0.5 - 2.1	2800	9.80	249	1.5	0.69	1/8"	3/16"	11
14SCA03B	14SCA03Q	4 - 26	0.5 - 2.9	1900	10.00	254	1.5	0.70	1/8"	3/16"	11
14SCA04B	14SCA04Q	3 - 40	0.4 - 4.5	1100	9.80	249	1.5	0.66	1/8"	3/16"	11
14SCA05B	14SCA05Q	2 - 45	0.2 - 5.1	660	10.20	259	1.6	0.73	1/8"	3/16"	11
14SCA06B	14SCA06Q	2 - 45	0.2 - 5.1	260	10.20	259	1.6	0.74	1/8"	3/16"	11

*Add .63" (16mm) for bit & finder models

** Short housing

General:

90 psi (620kPa) required for maximum rated torque.

Standard Equipment:

Operating instructions & service manual.
Suspension bail.

All torque springs required to meet indicated torque.
Lever Push-to-Start models include kit to convert to lever only. (301409)

Optional Equipment:

Additional accessories: Pages 18-19

Bits & finders: Page 18

Non-Reverse Kit: 207030

Torque Signal Kit: 301106 (lever only)

Overhose: 207019

Model Number			Torque Range		Free Speed RPM	Length*		Weight		Air Consumption		
Bit & Finder	1/4" Hex Quick Change	3/8" Square Drive	in.-lbs.	Nm		in.	mm	lbs.	kg	Air Inlet NPT	Min. Hose I.D.	SCFM
Push-to-Start - Push Button Reverse												
8RSA-40	8RSA-40BQ		15 - 25	1.7 - 2.8	3200	8.9	241	2.1	1.0	1/4"	1/4"	19
8RSA-30	8RSA-30BQ		15 - 30	1.7 - 3.4	2500	8.9	241	2.1	1.0	1/4"	1/4"	19
8RSA-20	8RSA-20BQ		15 - 40	1.7 - 4.5	1800	8.9	241	2.1	1.0	1/4"	1/4"	19
8RSA-10	8RSA-10BQ		15 - 65	1.7 - 7.3	800	9.6	260	2.4	1.1	1/4"	1/4"	19
		8RSA-7BQ	15 - 75	1.7 - 8.5	550	9.6	260	2.4	1.1	1/4"	1/4"	19
		8RSA-5BQ	15 - 75	1.7 - 8.5	400	9.6	260	2.4	1.1	1/4"	1/4"	19
	88RSA-7CQ	88RSA-7C-3	15 - 95	1.7 - 10	550	9.5	241	2.6	1.2	1/4"	1/4"	19
	88RSA-5CQ	88RSA-5C-3	15 - 160	1.7 - 18	400	9.5	241	2.6	1.2	1/4"	1/4"	19
Push-to-Start - Non-Reversible												
	8SA-20BQ		15 - 42	1.7 - 4.7	2000	8.5	232	2.0	0.9	1/4"	1/4"	19
8SA-10	8SA-10BQ		15 - 67	1.7 - 7.6	1000	9.1	251	2.3	1.0	1/4"	1/4"	19
	8SA-7BQ		15 - 75	1.7 - 8.5	650	9.1	251	2.3	1.0	1/4"	1/4"	19
	88SA-7CQ		15 - 100	1.7 - 11	650	9.1	232	2.5	1.1	1/4"	1/4"	19
	88SA-5CQ	88SA-5C-3	15 - 170	1.7 - 19	500	9.1	232	2.5	1.1	1/4"	1/4"	19
Push and Lever Start - Push Button Reverse												
8RSAL-20	8RSAL-20BQ		15 - 38	1.7 - 4.3	1800	10.5	282	2.6	1.2	1/4"	1/4"	19
	8RSAL-10BQ		15 - 60	1.7 - 6.8	800	11.3	302	2.9	1.3	1/4"	1/4"	19
	88RSAL-5CQ	88RSAL-5C-3	15 - 160	1.7 - 18	400	11.1	282	3.1	1.4	1/4"	1/4"	19
Inline - Push-to-Start - Push Button Reverse												
	35RSA-20Q		15 - 60	1.7 - 7	1250	9.6	244	2.5	1.1	1/4"	5/16"	24
	35RSA-10Q	35RSA-10-3	15 - 110	1.7 - 12	620	10.4	264	2.8	1.2	1/4"	5/16"	24
	35RSA-7Q		15 - 160	1.7 - 18	410	10.4	264	2.8	1.2	1/4"	5/16"	24
	35RSA-5Q	35RSA-5-3	15 - 180	1.7 - 20	300	10.4	264	2.8	1.2	1/4"	5/16"	24

*Add .63" (16mm) for bit & finder models

General:

90 psi (620kPa) required for maximum rated torque.

Length and weight of finder type tools includes standard length bit & finder.

Weight does not include dead handle.

Standard Equipment:

Operating instructions & service manual
Suspension bail

Dead handle on models above 100 in.lbs. torque cap.
All torque springs required to meet indicated torque

Standard Equipment if Specified:

One bit, finder, and finder spring (bit & finder models)

Grip Sleeve (202346; Push-to-Start models only)

Dead handle (861006)

Optional Equipment:

Additional accessories: Pages 18-19

Bits & finders: Page 18

Torque Springs: Page 19

Pistol Grip Screwdrivers

14 Series Clecomatic Clutch

Cleco®

14 Series

Torque Range: .2 – 14.7 Nm 2.0 – 130 In. Lbs.

- Sliding knob reverse
- External torque adjustment
- Quick change drive
- Convenient top, bottom and rear air inlet (T-handle models)
- Torque signal ports provided
- Trigger and Push & Trigger start



14TCA04Q
"T" Handle

The "T" handle is best for applications that are pre-threaded and the grip on the tool is required to simply guide the tool as the fastener is being tightened.



14PTA04Q
"P" Handle

The "P" handle is best suited for thread cutting fasteners where force must be exerted against the ergonomically shaped "P" handle during the process.



Model Number	Torque Range		Free Speed	Length		Weight		Air Consumption			
	1/4" Quick Change	in.-lbs.		Nm	RPM	in.	mm	lbs.	kg	Air Inlet NPT	Min. Hose I.D.
Push and Trigger Start - T Handle - Clecomatic Clutch											
14TCA02Q		4 - 19	0.5 - 2.1	2800	8.4	214	1.8	0.8	1/8"	3/16"	11
14TCA03Q		4 - 26	0.5 - 2.9	1900	8.6	219	1.9	0.8	1/8"	3/16"	11
14TCA04Q		3 - 40	0.3 - 4.5	1100	8.4	214	1.9	0.8	1/8"	3/16"	11
14TCA05Q		2 - 45	0.2 - 5.1	660	8.8	224	1.9	0.9	1/8"	3/16"	11
14TCA06Q		2 - 45	0.2 - 5.1	260	8.8	224	1.9	0.9	1/8"	3/16"	11
Trigger Start - T Handle - Clecomatic Clutch											
14TTA02Q		4 - 19	0.5 - 2.1	2800	8.3	211	1.8	0.8	1/8"	3/16"	11
14TTA03Q		4 - 26	0.5 - 2.9	1900	8.5	216	1.9	0.8	1/8"	3/16"	11
14TTA04Q		3 - 40	0.3 - 4.5	1100	8.3	211	1.9	0.8	1/8"	3/16"	11
14TTA05Q		2 - 45	0.2 - 5.1	660	8.7	221	1.9	0.9	1/8"	3/16"	11
14TTA06Q		2 - 45	0.2 - 5.1	260	8.7	221	1.9	0.9	1/8"	3/16"	11
14TTA07Q		21 - 60	2.4 - 6.8	660	10.0	255	2.3	1.0	1/8"	3/16"	11
14TTA10Q		30 - 87	3.4 - 9.8	400	10.2	260	2.3	1.1	1/8"	3/16"	11
14TTA15Q		35 - 130	4.0 - 14.7	250	10.0	255	2.3	1.0	1/8"	3/16"	11

General:

Tool performance rated at 90 psi (620kPa) air pressure.

Standard Equipment:

Operating instructions & service manual
Suspension bail

Dead handle on models above 100 in.-lbs. torque cap.
All torque springs required to meet indicated torque specification

Optional Equipment:

Additional accessories: Pages 18-19

Non-Reverse Kit: 207030
Torque Springs: Page 19
Torque Signal Kit: 301118
(Trigger w/Clecomatic clutch only)
Overhose: 207107
Push-only Conversion Kit: 301121

Model Number	Torque Range		Free Speed	Length		Weight		Air Consumption			
	1/4" Quick Change	in.-lbs.		Nm	RPM	in.	mm	lbs.	kg	Air Inlet NPT	Min. Hose I.D.
Push and Trigger Start - P Handle - Clecomatic Clutch											
14PCA02Q		4 - 19	0.5 - 2.1	2800	8.2	208	1.7	0.8	1/8"	3/16"	11
14PCA03Q		4 - 26	0.5 - 2.9	1900	8.4	213	1.8	0.8	1/8"	3/16"	11
14PCA04Q		3 - 40	0.3 - 4.5	1100	8.2	208	1.7	0.8	1/8"	3/16"	11
14PCA05Q		2 - 45	0.2 - 5.1	660	8.6	218	1.8	0.8	1/8"	3/16"	11
14PCA06Q		2 - 45	0.2 - 5.1	260	8.6	218	1.8	0.8	1/8"	3/16"	11
Trigger Start - P Handle - Clecomatic Clutch											
14PTA02Q		4 - 19	0.5 - 2.1	2800	8.1	205	1.7	0.8	1/8"	3/16"	11
14PTA03Q		4 - 26	0.5 - 2.9	1900	8.3	210	1.8	0.8	1/8"	3/16"	11
14PTA04Q		3 - 40	0.3 - 4.5	1100	8.1	205	1.7	0.8	1/8"	3/16"	11
14PTA05Q		2 - 45	0.2 - 5.1	660	8.5	215	1.8	0.9	1/8"	3/16"	11
14PTA06Q		2 - 45	0.2 - 5.1	260	8.5	215	1.8	0.9	1/8"	3/16"	11
14PTA07Q		21 - 60	2.4 - 6.8	660	9.8	249	2.2	1.0	1/8"	3/16"	11
14PTA10Q		30 - 87	3.4 - 9.8	400	10.0	254	2.2	1.0	1/8"	3/16"	11
14PTA15Q		35 - 130	4.0 - 14.7	250	9.8	249	2.2	1.0	1/8"	3/16"	11

General:

Tool performance rated at 90 psi (620kPa) air pressure.

Standard Equipment:

Operating instructions & service manual
Suspension bail

Dead handle on models above 100 in.-lbs. torque cap.
All torque springs required to meet indicated torque specification

Optional Equipment:

Additional accessories: Pages 18-19

Non-Reverse Kit: 301120
Torque Springs: Page 19
Torque Signal Kit: 301119
(Trigger w/Clecomatic clutch only)

Pistol Grip Screwdrivers

8, 88 & 35 Series Clecomatic Clutch

Cleco®

8 Series

Torque Range: 1.7 – 85 Nm 15 – 75 In. Lbs.

- Bit and finder and quick change
- Reversible
- Trigger, Push-to-Start and Push & Trigger start



88 Series

Torque Range: 1.7 – 20 Nm 15 – 180 In. Lbs.

- Quick change and square drive
- Reversible
- Trigger and Push & Trigger start

35 Series

Torque Range: 1.7 – 20 Nm 15 – 180 In. Lbs.

- Pistol grip
- Quick change and square drive
- Reversible
- Trigger, Push-to-Start and Push & Trigger start



Model Number		Torque Range		Free Speed	Length		Weight		Air Consumption		
1/4" Hex Quick Change	3/8" Square Drive	in.-lbs.	Nm	RPM	in.	mm	lbs.	kg	Air Inlet NPT	Min. Hose I.D.	SCFM
		Push-to-Start - Sliding Knob Reverse									
		15 - 40	1.7 - 4.5	1800	8.5	216	2.8	1.3	1/4"	1/4"	19
		15 - 65	1.7 - 7.3	800	9.3	235	3.0	1.4	1/4"	1/4"	19
		15 - 75	1.7 - 8.5	550	9.3	235	3.0	1.4	1/4"	1/4"	19
Push and Trigger Start - Sliding Knob Reverse											
		15 - 25	1.7 - 2.8	3200	8.5	216	2.8	1.3	1/4"	1/4"	19
		15 - 40	1.7 - 4.5	1800	8.5	216	2.8	1.3	1/4"	1/4"	19
		15 - 65	1.7 - 7.3	800	9.3	235	3.0	1.4	1/4"	1/4"	19
		15 - 75	1.7 - 8.5	550	9.3	235	3.0	1.4	1/4"	1/4"	19
		15 - 75	1.7 - 8.5	400	9.3	235	3.0	1.4	1/4"	1/4"	19
		15 - 95	1.7 - 10	550	9.0	229	3.1	1.4	1/4"	1/4"	19
	88RSAPT-5C-3	15 - 160	1.7 - 18	400	9.0	229	3.1	1.4	1/4"	1/4"	19
		15 - 180	1.7 - 20	200	9.8	248	3.4	1.5	1/4"	1/4"	19
Trigger Start - Sliding Knob Reverse											
		15 - 30	1.7 - 3.4	2500	8.4	213	2.8	1.3	1/4"	1/4"	19
		15 - 40	1.7 - 4.5	1800	8.4	213	2.8	1.3	1/4"	1/4"	19
		15 - 65	1.7 - 7.3	800	9.1	232	3.0	1.4	1/4"	1/4"	19
		15 - 75	1.7 - 8.5	550	9.1	232	3.0	1.4	1/4"	1/4"	19
		15 - 75	1.7 - 8.5	400	9.1	232	3.0	1.4	1/4"	1/4"	19
	88RSATP-7C-3	15 - 95	1.7 - 10	550	8.9	225	3.1	1.4	1/4"	1/4"	19
	88RSATP-5C-3	15 - 160	1.7 - 18	400	8.9	225	3.1	1.4	1/4"	1/4"	19
	88RSATP-2C-3	15 - 180	1.7 - 20	200	9.6	245	3.4	1.5	1/4"	1/4"	19

General:
Tool performance rated at 90 psi (620kPa).
Weight does not include dead handle

Standard Equipment:
Operating instructions & service manual
Dead handle on all models above 100 in.lbs. torque
All torque springs required to meet indicated torque

Optional Equipment:
Additional accessories: Pages 18-19
Bits & finders: Page 18
Torque Springs: Page 19

Standard Equipment if Specified:
Dead handle (861006)

Model Number		Torque Range		Free Speed	Length		Weight		Air Consumption		
1/4" Hex Quick Change	3/8" Square Drive	in.-lbs.	Nm	RPM	in.	mm	lbs.	kg	Air Inlet NPT	Min. Hose I.D.	SCFM
		Push-to-Start - Sliding Knob Reverse									
		15 - 60	2 - 7	1550	9.1	232	3.1	1.4	1/4"	5/16"	24
		15 - 110	2 - 12	770	9.9	251	3.4	1.5	1/4"	5/16"	24
		15 - 160	2 - 18	510	9.9	251	3.4	1.5	1/4"	5/16"	24
Push and Trigger Start - Sliding Knob Reverse											
		15 - 60	2 - 7	1500	9.1	232	3.1	1.4	1/4"	5/16"	24
		15 - 110	2 - 12	750	9.9	251	3.4	1.5	1/4"	5/16"	24
		15 - 160	2 - 18	500	9.9	251	3.4	1.5	1/4"	5/16"	24
		15 - 180	2 - 20	350	9.9	251	3.4	1.5	1/4"	5/16"	24
Trigger Start - Sliding Knob Reverse											
		15 - 60	2 - 7	1500	9.0	229	3.1	1.4	1/4"	5/16"	24
	35RSATP-10-3	15 - 110	2 - 12	750	9.8	248	3.4	1.5	1/4"	5/16"	24
		15 - 160	2 - 18	500	9.8	248	3.4	1.5	1/4"	5/16"	24
	35RSATP-5-3	15 - 180	2 - 20	350	9.8	248	3.4	1.5	1/4"	5/16"	24

General:
Tool performance rated at 90 psi (620kPa).
Weight does not include dead handle

Standard Equipment:
Operating instructions & service manual
Dead handle on all models above 100 in.lbs. torque
All torque springs required to meet indicated torque

Standard Equipment if Specified:
Dead handle (861006)
Optional Equipment:
Additional accessories: Pages 18-19
Torque Springs: Page 19

Screwdrivers

14 & 8 Series Stall

Cleco®

14 & 8 Series Stall

Torque Range: 2.1 – 12.4 Nm 19 – 110 In. Lbs.

- Pistol
- 1/4" hex quick change drive
- Trigger start
- Convenient top, bottom and rear air inlet (14 Series T-handle models)
- "P" and "T" style handles (14 series)
- Sliding knob reverse (8 & 14 series)
- Push button reverse (8 series)



Model Number	Torque Range		Free Speed RPM	Length		Weight		Air Consumption		
	in.-lbs.	Nm		in.	mm	lbs.	kg	Air Inlet NPT	Min. Hose I.D.	SCFM
Trigger Start - T Handle - Sliding Knob Reverse										
14TTS02Q	19	2.1	2800	6.5	166	1.6	0.7	1/8"	3/16"	11
14TTS03Q	27	3.1	1900	6.8	171	1.6	0.7	1/8"	3/16"	11
14TTS04Q	40	4.5	1100	6.5	166	1.6	0.7	1/8"	3/16"	11
14TTS05Q	45	5.1	660	6.9	175	1.8	0.8	1/8"	3/16"	11
8RNP-20BQ	44	5.0	1800	5.4	137	2.1	1.0	1/4"	1/4"	19
8RNP-10BQ	70	7.9	800	6.1	156	2.4	1.1	1/4"	1/4"	19
Trigger Start - P Handle - Sliding Knob Reverse										
14PTS02Q	19	2.1	2800	6.3	161	1.5	0.7	1/8"	3/16"	11
14PTS03Q	27	3.1	1900	6.5	166	1.5	0.7	1/8"	3/16"	11
14PTS04Q	40	4.5	1100	6.3	161	1.5	0.7	1/8"	3/16"	11
14PTS05Q	45	5.1	660	6.7	170	1.7	0.8	1/8"	3/16"	11
Trigger Start - Pistol Grip - Push Button Reverse										
8RNO-20BQ	44	5.0	1800	6.0	152	2.0	0.9	1/4"	1/4"	19
8RNO-10BQ	70	7.9	800	6.8	171	2.3	1.0	1/4"	1/4"	19
8RNO-7BQ	110	12.4	550	6.8	171	2.3	1.0	1/4"	1/4"	19

General:

Tool performance rated at 90 psi (620kPa).

Standard Equipment:

Operating instructions & service manual

Suspension ball

All torque springs required to meet indicated torque

Dead handle on all models above 100 in.lbs. torque

Standard Equipment if Specified:

Dead handle (861006; 8 series models)

Optional Equipment:

Additional accessories: Pages 24-26

Bits: Page 24

Non-Reverse Kit:

14 series T Handle: 207030

14 series P Handle: 301120

Overhose:

14 series T Handle: 207107

Screwdrivers

Model Number Nomenclature

Cleco 2 Series

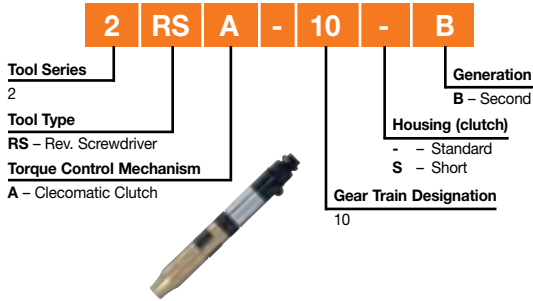

Cleco 14 Series

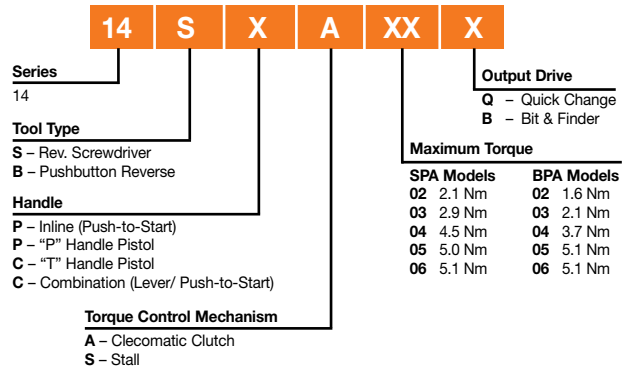

Cleco 8 Series

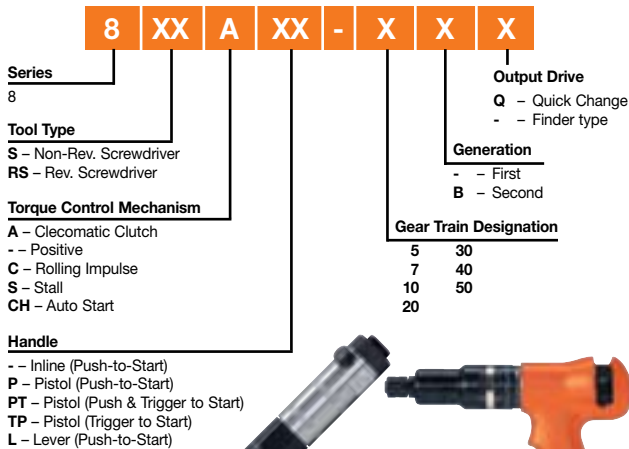

Cleco 88 Series

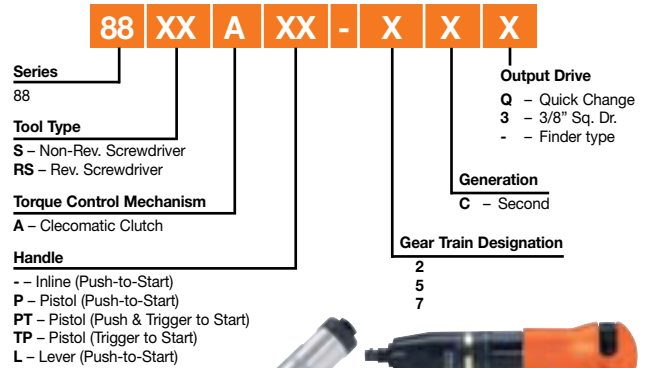

Cleco 35 Series

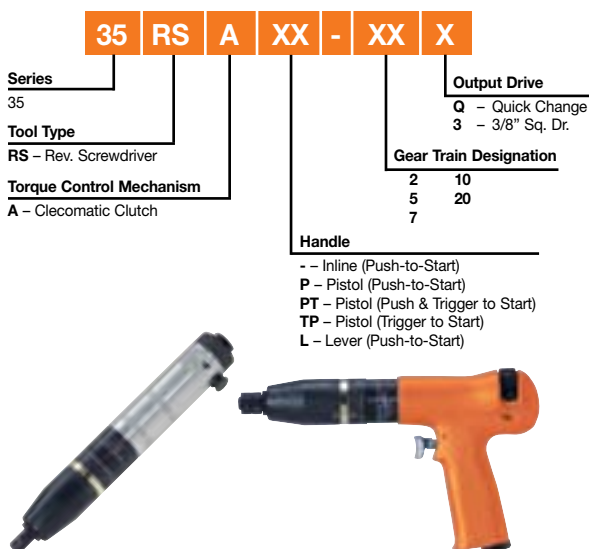

Screwdriver Accessories

Standard and Extended Flat Bits and Finders

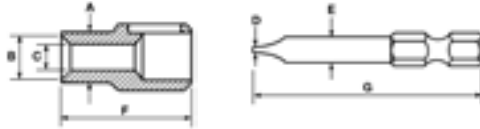

Screw Size	Standard Length (F=1 3/16 in.; G= 1 15/16 in.)		Finder Dimensions (in.)			Bit Dimensions (in.)		Extended Length (F=2 1/4 in.; G= 3 in.)	
	Bit No.	Finder No.	A	B	C	D	E	Bit No.	Finder No.
1F- 2R	849617	847299	.22	.169	.128	.026	.122	849891	847481
2F- 3R	849843	863242	.250	.196	.140	.028	.134	849879	847480
3F- 4R	849618	847300	.285	.228	.160	.032	.154	849892	847482
4F- 5R	849153	847301	.315	.259	.193	.034	.187	849893	847483
5F- 6R	849619	847302	.345	.291	.221	.036	.215	849894	847484
6F- 8R	849154	847303	.380	.323	.256	.038	.250	849895	847485
8F-10R	849620	847294	.445	.386	.281	.042	.275	849896	847486
10F-12R	849155	847304	.530	.431	.318	.046	.312	849897	847487
12F-14R	849156	847305	.590	.513	.366	.050	.360	849898	847488

Finder Springs

Light Force

844000

Medium Force

865728

Phillips Bits and Support Bushings



Phillips Bit Point Size	Bit Body Diameter (in.)	Phillips Bit Part No.	Support Bushing* Part No.
Standard: 1/4 in. Hex Shank Bit – 2 3/4 in. O.A. Length; Bushing – 1 3/16 in. O.A. Length			
1	3/16	809451	847301
2	1/4	809470	847303
3	5/16	809471	847304
Extended: 1/4 in. Hex Shank Bit – 3 1/2 in. O.A. Length; Bushing – 2 1/4 in. O.A. Length			
1	3/16	809453	847483
2	1/4	809473	847485
3	5/16	809474	847487

*Bushing not required on Quick Change models.

Bit Holders and Support Bushings



1/4" Hex Drive Magnetic Bit Holder
Part No. 849325 (2 3/8" O.A. Length)
Magnetic Support Bushing* Part No. 849621
Nonmagnetic Support Bushing* Part No. 847245
Quick-Change Bushing Part No. 201203
Fits all finder type tools except No. 2 Screwdriver
*Bushing not required on Quick Change models.

Screw Sizes & Types



Screw Size	Approximate Thread Body Diameter (inches)	Maximum Head Diameter (inches)							Width of Slot Max. - Min. (inches)
		Round Head	Flat Head	Oval Head	Fillister Head	Pan Head	Binding Head	Truss Head	
0	.058	.113	.119	.119	.096	.116	-	.131	.023 - .016
1	.071	.138	.146	.146	.118	.142	-	.164	.026 - .019
2	.084	.162	.172	.172	.140	.167	.181	.194	.031 - .023
3	.096	.187	.199	.199	.161	.193	.208	.226	.035 - .027
4	.109	.211	.225	.225	.183	.219	.235	.257	.039 - .031
5	.122	.236	.252	.252	.205	.245	.263	.289	.043 - .035
6	.135	.260	.279	.279	.226	.270	.290	.321	.048 - .039
8	.161	.309	.332	.332	.270	.322	.344	.384	.054 - .045
10	.187	.359	.385	.385	.313	.373	.399	.448	.060 - .050
12	.213	.408	.438	.438	.357	.425	.454	.511	.067 - .056
1/4	.247	.472	.507	.507	.414	.492	.513	.573	.075 - .064
5/16	.309	.590	.635	.635	.518	.615	.641	.698	.084 - .072

Screwdrivers – Clutch Torque Springs

Spring Color	Torque Range		Ordering No.
	In. Lbs.	Nm	
2 Series			
Blue	1.5-.5	17-.06	202870
Green	8-1	.9-.1	202869
14 Series			
Blue	8-2	.9-.23	203580
Purple	11-2	1.2-.23	204322
Green	19-5	2.1-.6	203579
White	38-10	4.3-1.1	203575
Yellow	45-15	5.1-1.7	203578
8 Series			
Blue	17-7	1.9-.8	869203
Green	55-15	6.2-1.7	867938
Red	75-35	8.5-4	867931
88, 35 Series			
Green	55-15	6-2	202822
Yellow	160-35	18-4	869306
Red	180-60	20-7	869305

Note: Torque listed is immediately after the clutch and does not take into consideration torque multiplication after the clutch, such as additional planetary gears or right angle heads.

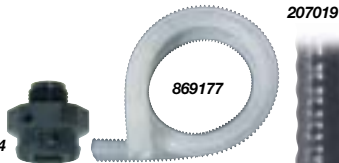

Exhaust Overhose & Adapter

Order No.	Description	Used On
207019	Overhose	14 series inline & right angle
207107	Overhose	14 series "T" handle pistol
869204	Adapter	8, 88, 35 series inline, push-to-start

Piped Away Exhaust Hose Adapter



Order No.	Used On
203632	5 series inline
203808	8, 88, 35 series inline p-t-start

Portable Tool Balancers

Part Number	Capacity		Net Weight	Min. Distance Hook to Hook	Length of Working Cable
	Max.	Min.			
200427	2 lbs.	0 lbs.	1.25 lbs.	10.8 in.	5.0 ft.
200428	4 lbs.	2 lbs.	1.25 lbs.	10.8 in.	5.0 ft.
200429	5 lbs.	3 lbs.	1.25 lbs.	10.8 in.	5.0 ft.
PL-12A	12 lbs.	1 lbs.	-	6.8 in.	4.6 ft.
BL-2A	2 lbs.	1 lbs.	1.1 lbs.	10.4 in.	5.2 ft.
BL-4A	4 lbs.	2 lbs.	1.1 lbs.	10.4 in.	5.2 ft.

Dead Handle

Ordering No.	Used On
201770	5 series, 14 series
861006	8, 88, 35 series



Handle Grips

Order No.	Grip Type	Used On
202464	Round inline	2 series
869734	Round inline	5 series
203621	Tri-roundular inline	5 series
202346	Round inline	8 series p-t-start
203762	Pistol grip	5 series
203833	Pistol grip	8, 88, 35 series



Suspension Bails

Order No.	Used On
931962	14 series
869168	2 series
865777	5 series inline & 8, 88 series inline push-to-start
412603	5 series pistol grip & 8, 88 series inline lever start





Cleco®

Screwdriver balance arms absorb torque, support weight and improve productivity.

Cleco balance arms are engineered to deliver longer service life using durable components, rugged design and operator-sensitive features.

These arms absorb the torque produced by the screwdriver, eliminating torque reaction to the operator. Balanced by springs or air cylinders, the arm and not the operator supports the weight of the tool. By reducing the fatigue factors, the operator productivity is improved.

Tool movement and placement over the fastener is virtually effortless since most moving parts of the balance arm are mounted on ball bearings. Access to the tool is easily changeable by adjusting the springs or cylinder supporting the forearm.

Arm components and materials are selected for strength and rigidity. Precision aluminum sand castings used in the articulating arm section are light but sturdy.

Over 25 models of the Cleco screwdriver balance arms are available. Air cylinder models are capable of supporting tools weighing up to 10 lbs. (4.5 kg.). Spring models will support tools weighing up to 5 lbs. (2.3 kg.). Both styles have torque capacities of 10 ft. lbs. (13.5 Nm). Arms can be post mounted, wall mounted or mounted on an adjustable height post. Tool holders for all models will accommodate most major brands of air tools...straight and pistol.

Tool Holders

Selecting the proper tool holder for the tool used on Cleco balance arms enhances the ergonomic benefits of the arm. Tool holders allow the tool to swing, swivel and rotate, enabling the operator to work more comfortably and productively.

Standard and extended tool holders are available for parallel balance arms. Both models hold the tool perpendicular to the work, and are ideal for self-tapping and thread forming applications. Tool diameter capacity is up to 1 3/4 inch (45mm).

Manifold tool holders used on SBA and CSBA balance arms suspend the tool from the air inlet. They allow the tool to swing (or swivel when equipped with the optional swivel assembly) for ease of tool movement.

Balance Arms

Air Cylinder & Spring

Cleco®

- Ball bearing construction
- Supports tools weighing up to 5 lbs. (spring models) or up to 10 lbs. (air cylinder models).
- Post, wall, or adjustable height post mounting
- Single or parallel arms

*Air Cylinder
Single Arm Post
CPBA-18*

*Air Cylinder
Parallel Arm
Adjustable Height
CPBA-18-AH*

*Spring
Parallel Arm Post
PBA-18*

*Spring
Single Arm
Adjustable Height
SBA-18-AH*

Post mounting template

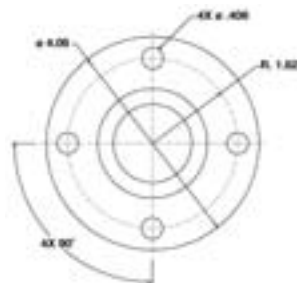

TOOLS NOT INCLUDED

Single Arms		Parallel Arms		Dimensions							
Model No.	Code No.	Model No.	Code No.	A		B		C		D	
				in.	mm	in.	mm	in.	mm	in.	mm
Air Cylinder Models											
CSBA18	520160	CPBA-18	520170	12	305	18	457	18	457	-	-
CSBA-24	520200			12	305	24	610	18	457	-	-
CSBA-30	520201	CPBA-30	520203	12	305	30	762	18	457	-	-
CSBA-12-AH	520165	CPBA-12-AH	520178	12	305	12	305	-	-	30	762
CSBA-18-AH	520162	CPBA-18-AH	520172	12	305	18	457	-	-	30	762
CSBA-30-AH	520167	CPBA-30-AH	520215	12	305	30	762	-	-	30	762
		CPBA-30-WM	520207	12	305	30	762	-	-	-	-

AH = Adjustable Height
 WM = Wall Mounted
 Tool weight capacity: 10 lbs. (4.6 kg)
 Torque capacity: 10 ft. lbs. (13.5 Nm)

Standard Equipment
 Operating Instructions and Service Manual.
 Regulator for Air Cylinders.
 Threaded Nipples for CSBA Models
 1/4 NPT Hex Nipple: 204032
 1/4 NPT x 1/8 NPT Hex Reducer
 Nipple: 204137

Optional Equipment
 Additional accessories: See page 30.

Single Arms		Parallel Arms		Dimensions							
Model No.	Code No.	Model No.	Code No.	A		B		C		D	
				in.	mm	in.	mm	in.	mm	in.	mm
Spring Models											
SBA-12	520001	PBA-12	520007	12	305	12	305	18	457	-	-
SBA-18	520004	PBA-18	520010	12	305	18	457	18	457	-	-
		PBA-24	520045	12	305	24	610	18	457	-	-
SBA-12-AH	520003	PBA-12-AH	520009	12	305	12	305	-	-	30	762
SBA-18-AH	520006	PBA-18-AH	520012	12	305	18	457	-	-	30	762
SBA-24-AH	520110	PBA-24-AH	520047	12	305	24	610	-	-	30	762
SBA-30-AH	520044	PBA-30-AH	520050	12	305	30	762	-	-	30	762
		PBA-18-18-AH	520036	18	457	18	305	-	-	30	762
		PBA-12-WM	520008	12	305	12	305	-	-	-	-
SBA-30-WM	520043			12	305	30	762	-	-	-	-

AH = Adjustable Height
 WM = Wall Mounted
 Tool weight capacity: 5 lbs. (2.3 kg)
 Torque capacity: 10 ft. lbs. (13.5 Nm)

Standard Equipment
 Operating Instructions and Service Manual.
 Threaded Nipples for SBA Models
 1/4 NPT Hex Nipple: 204032
 1/4 NPT x 1/8 NPT Hex Reducer
 Nipple: 204137

Optional Equipment
 Additional accessories: See page 24.

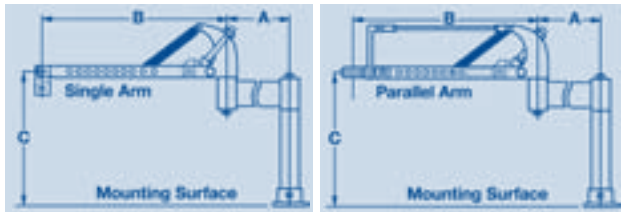

Balance Arm Operating Envelope

MODEL	R1 MAX		R1 MIN		R2 MAX		R2 MIN		H MAX		H MIN	
	in.	mm	in.	mm	in.	mm	in.	mm	in.	mm	in.	mm
SBA-12	24	610	2	51	18	457	8	203	15	381	6	152
SBA-18	30	762	6	152	20	508	7	178	15	381	0	0
PBA-12	26	660	3	76	20	508	7	178	17	432	8	203
PBA-18	32	813	8	203	22	559	6	152	17	432	2	51

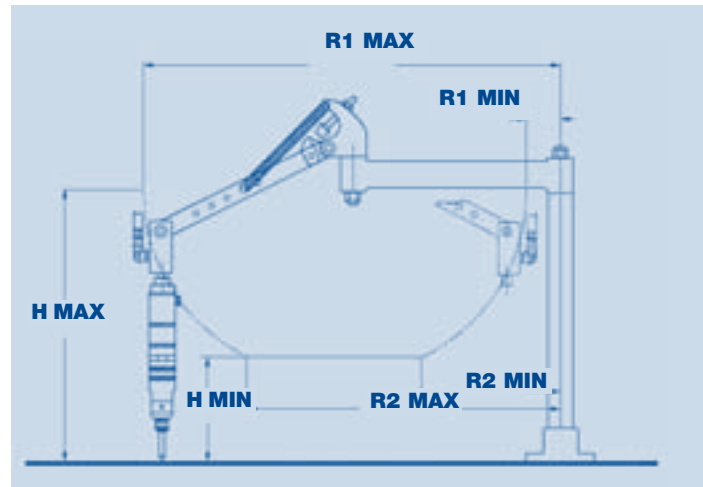

XX BA - XX - XX - XX

Series
 CS - Air cylinder, single arm
 S - Spring, single arm
 CP - Air cylinder, parallel arm
 P - Spring, parallel arm

Tool Type
 BA - Balance Arm

Arm Extension
 12" 24"
 18" 30"
 (12" unless specified)

Mount
 - - Post
 AH - Adjustable Height
 WM - Wall Mount

Adjustable Arm Extension
 12" 24"
 18" 30"

Balance Arms

Accessories

Single Arm Tool Holders

Part Number	Description
201690*	Manifold tool holder
201601*	Swivel manifold tool holder

*Use of 201601 requires 201690.

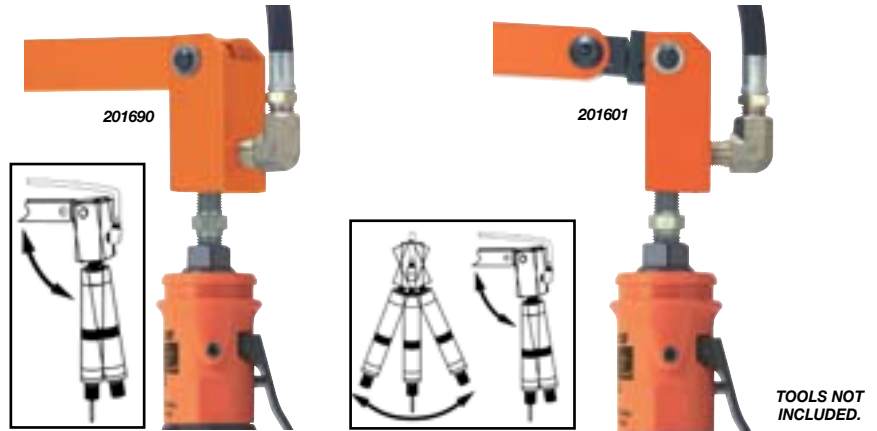

Parallel Arm Tool Holders

Part Number	Description
201675	Parallel tool holder
204167	Extended parallel tool holder
201607	Swivel tool holder (small)
201608	Swivel tool holder (large)

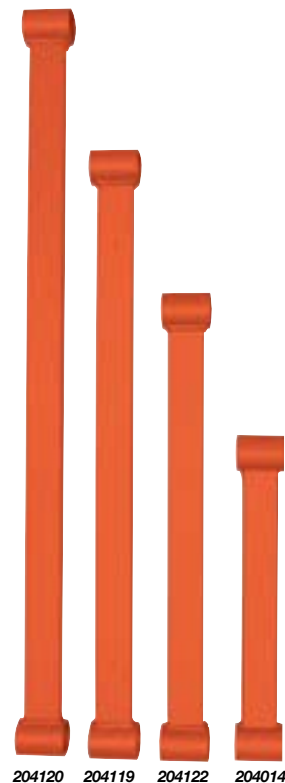
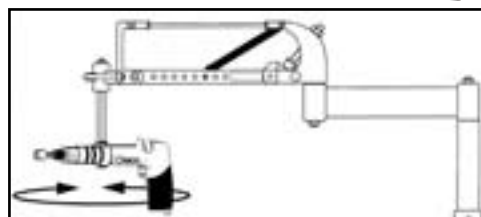

Articulating Arm Extensions

Part Number	Length (inches)
204014	12
204122	18
204119	24
204120	30

Conversion Kits for Cleco Screwdriver Balance Arms

To Convert Balance Arms		Part No.
From	To	
SBA-12	PBA-12*	521041
SBA-18	PBA-18*	521042
Spring	Cylinder	201606
SBA or PBA Standard Duty	SBA or PBA Heavy Duty**	521060

* Conversion kits for -24 and -30 models are available upon request.

** Has four springs to support heavier tools or longer arms.

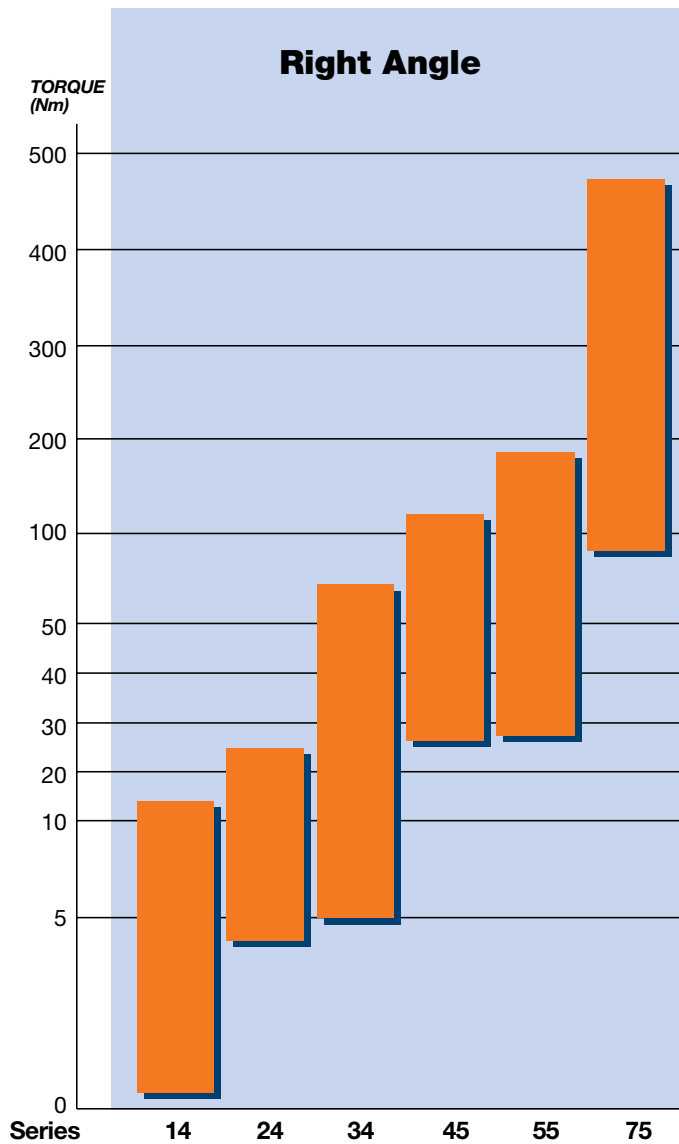

Cleco®

Selecting Your Cleco Nutrunner

Cleco offers over 500 nutrunners, most of which can be equipped with a wide variety of drive options. This generates over 3,000 different nutrunner combinations, allowing the exact tool with precise features to be chosen for specific job applications.

The following items should be considered before selecting the tool: ergonomic factors associated with the man/tool/task relationship, torque and speed requirements, tool and fastener accessibility, fastener joint variations, operator skill level and air supply.

Tool performance can be affected by air supply. Plant air line pressure to the tool will vary widely due to several factors: distance of tool from compressor; size of transmission lines, air drops, manifolds, hose length and diameter, and fittings. All power tool specifications are based on the tool receiving air at 90 p.s.i.g. (6.2 bar) with adequate air flow volume while the tool is running.

Clean Operation

Many Cleco angle nutrunners are equipped with oilless blades. This is a very important feature where a clean assembly operation is critical.



Angle Nutrunners

Clecomatic Nutrunners

Clecomatic nutrunners shut off the instant the clutch reaches its adjustable preset torque. This action provides an accurate method of controlling torque without sacrificing tool speed.

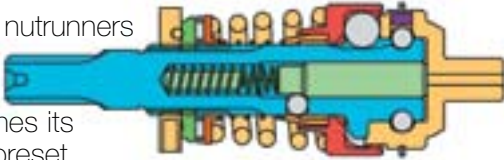

Stall Nutrunners

Stall-type nutrunners consist of an air motor connected to the output spindle by planetary gearing and angle heads. In operation, the tool runs down the fastener until the torque resistance in the fastener causes the tool to stall. When the tool stalls, the throttle is released by the operator and the tool is removed. Stall-type tools can produce accurate torques, especially on applications with varying torque rates; however, their torque output can be

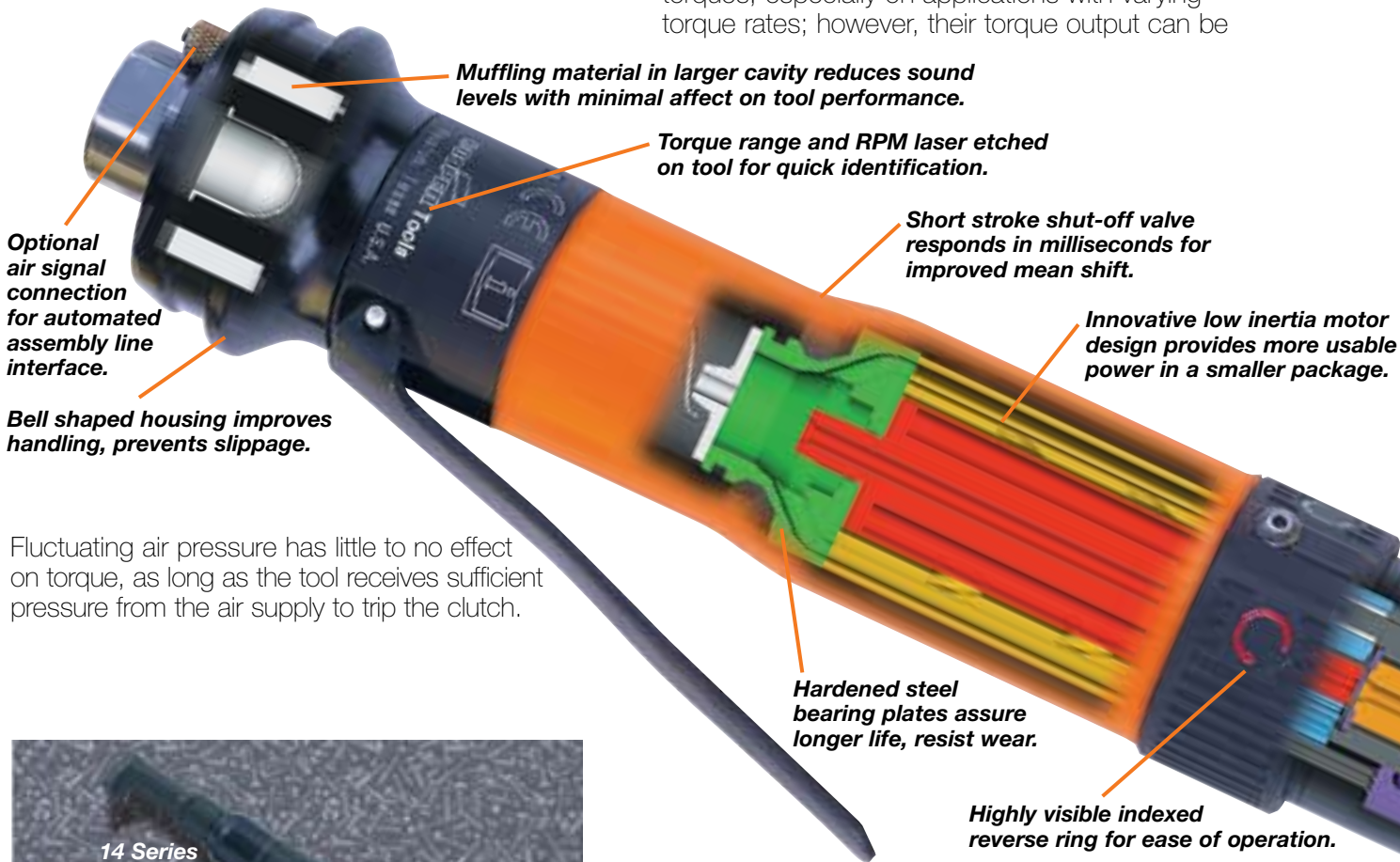

Fluctuating air pressure has little to no effect on torque, as long as the tool receives sufficient pressure from the air supply to trip the clutch.



easily influenced by the operator and by fluctuations in the air line pressure. Operators should be instructed to allow the tool to stall before releasing the throttle and to avoid pulling or wrenching the tool after it stalls.

The Cleco Right Angle Solution

The Cleco 14, 24 and 34 series pneumatic nutrunners are the most recent additions to our line of smaller, lighter and faster tools. These powerful right angle clutch tools cover a wide torque range from .5 to 68 NM. We continue to drive our line into the best power to weight ratio of any other tool in the market, in a relentless effort to offer the most performance, the highest level of accuracy and the greatest flexibility in its class of pneumatic tools.

We also design our tools to offer you reduced energy costs, longer operating life, fewer replacement parts and lower service costs.

Performance

The Cleco 24 and 34 series right angle nutrunners incorporate an innovative motor design that provides more usable power in a smaller package. This design contributes greatly to our smaller, lighter, faster goals and provides the highest power to weight ratio in its class to date.



Flexibility

Cleco nutrunners come with an externally adjusted and indicated clutch and offer improved ergonomics with a very comfortable handle area. The polymer coated angle heads on the 24 and 34 series reduce in-system damage. These durable heads are splined to allow indexing for better position. The operator will appreciate a quieter tool thanks to the composite exhaust deflector which also allows the exhaust to be efficiently piped away for even further reduced noise levels. These noted improvements are geared towards enhancing the tools positive operational features while reducing operator fatigue.

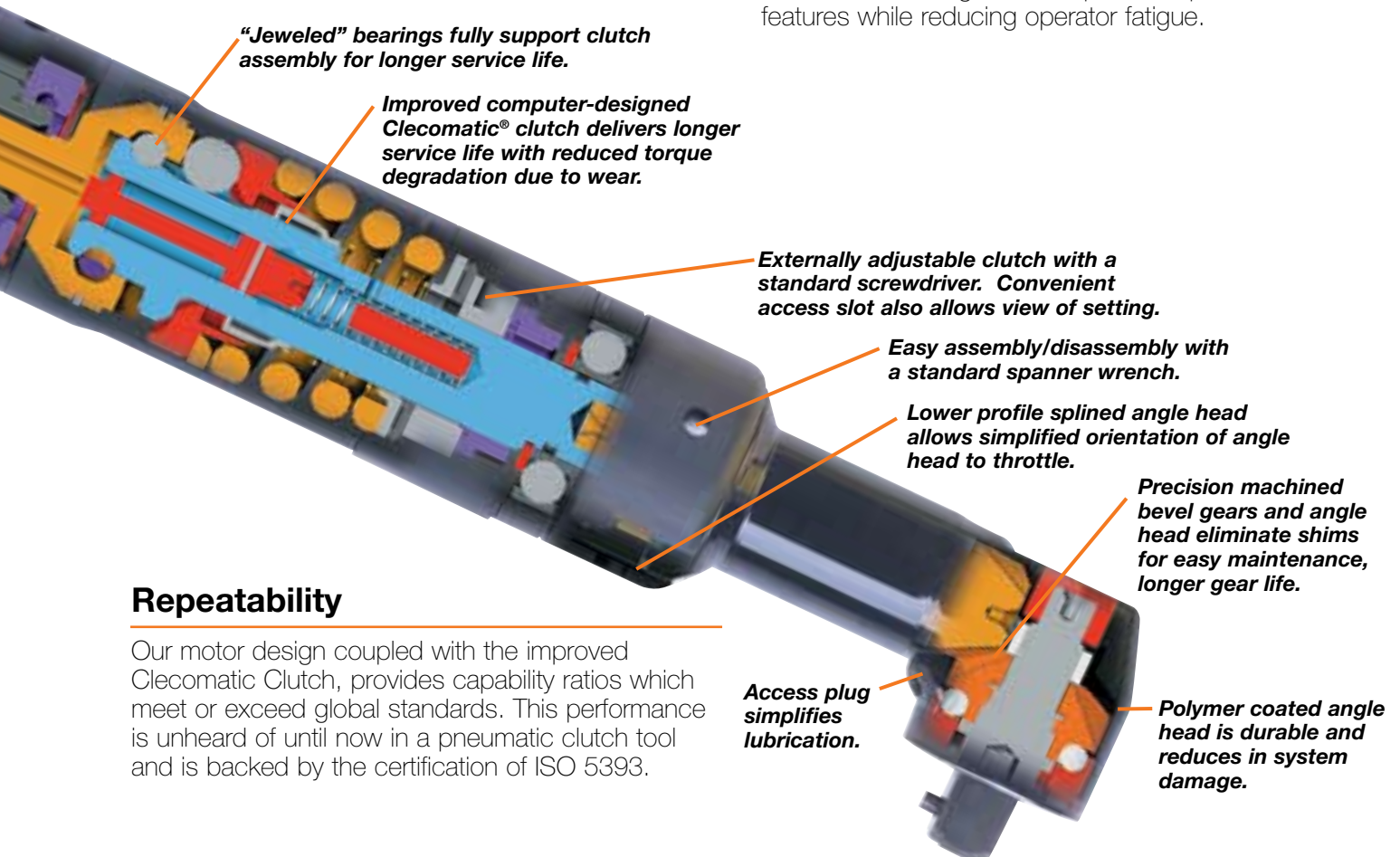

Repeatability

Our motor design coupled with the improved Clecomatic Clutch, provides capability ratios which meet or exceed global standards. This performance is unheard of until now in a pneumatic clutch tool and is backed by the certification of ISO 5393.

Angle Nutrunners

14, 24 & 34 Series Clecomatic Clutch

Cleco®

14 Series

Torque Range:

0.5 – 11 Nm 4.0 – 100 In. Lbs.

- External torque adjustment
- Sliding knob reverse
- 1/4" & 3/8" square drive

24 Series

Torque Range:

4.0 – 23 Nm 3.0 – 17 Ft. Lbs.

- External torque adjustment
- 3/8" square drive
- Indexable anglehead
- One torque spring to meet specified torque
- Oilless blades 

34 Series

Torque Range:

8.0 – 75 Nm 4.0 – 55 Ft. Lbs.

- External torque adjustment
- 3/8" and 1/2" square drive
- Indexable anglehead
- One torque spring to meet specified torque
- Oilless blades 



Model Number Example

24	R	A	A	23	A	M	3
Series 14 24 34	Rotation R-Reversible		Tool Style A – Right Angle	Torque Control A – Clecomatic S – Stall		Maximum Torque Nm (Rounded to the nearest Nm)	
				Square Drive 2 – 1/4" (AL only) 3 – 3/8" 4 – 1/2" (AZ only)		Angle Head Size L – Light Duty M – Medium Duty H – Heavy Duty X – Extra Heavy Duty Z – Super Heavy Duty	
						Tool Termination A Angle head	

Model Number		Torque Range*		Free Speed	Length		Weight		Head Height		Side to Center		Air Consumption		
1/4" Sq. Dr.	3/8" Sq. Dr.	in.-lbs.	Nm	RPM	in.	mm	lbs.	kg	in.	mm	in.	mm	Air Inlet NPT	Min. Hose I.D.	SCFM
14 Series - Reversible – Clecomatic Clutch															
14RAA02AM2		4 - 19	.5 - 2.1	2400	11.68	297	1.7	0.77	1.06	27	0.36	9	1/8"	3/16"	11
14RAA02AH2	14RAA02AH3	4 - 21	.5 - 2.4	2100	12.11	308	1.8	0.82	1.19	30	0.50	13	1/8"	3/16"	11
14RAA03AL2		4 - 25	.5 - 2.8	570	12.04	306	1.8	0.82	0.94	24	0.31	8	1/8"	3/16"	11
14RAA03AM2		4 - 27	.5 - 3.0	1650	11.88	302	1.8	0.82	1.06	27	0.36	9	1/8"	3/16"	11
14RAA03AH2	14RAA03AH3	4 - 30	.5 - 3.4	1450	12.31	313	1.9	0.86	1.19	30	0.50	13	1/8"	3/16"	11
14RAA04AM2		4 - 43	.5 - 4.8	950	11.68	297	1.7	0.77	1.06	27	0.36	9	1/8"	3/16"	11
14RAA05AM2		4 - 50	.5 - 5.7	570	12.08	307	1.8	0.82	1.06	27	0.36	9	1/8"	3/16"	11
14RAA06AH2*	14RAA06AH3	4 - 53	.5 - 6.0	850	12.11	308	1.8	0.82	1.19	30	0.50	13	1/8"	3/16"	11
14RAA07AH2*	14RAA07AH3	4 - 60	.5 - 6.8	500	12.51	318	1.9	0.86	1.19	30	0.50	13	1/8"	3/16"	11
14RAA09AH2*	14RAA09AH3	10 - 75	1.1 - 8.5	500	13.39	340	2.1	0.95	1.19	30	0.50	13	1/8"	3/16"	11
14RAA11AH2*	14RAA11AH3	10 - 100	1.1 - 11	340	13.59	345	2.2	1.00	1.19	30	0.50	13	1/8"	3/16"	11
14RAA12AH2*	14RAA12AH3	10 - 100	1.1 - 11	200	13.39	340	2.1	0.95	1.19	30	0.50	13	1/8"	3/16"	11

*AH2 head max torque 50 in. lbs.

General:

Tool performance rated at 90 psi (620kPa) air pressure.

Standard Equipment:

Operating instructions & service manual.
Suspension bail.

All torque springs required to meet indicated torque specification.

Optional Equipment:

Additional accessories: Page 46
Non-Reverse Kit: 207030
Torque Signal Kit: 301106 (Clecomatic clutch only)
Overhose: 207019

Quick Change and 1/4" magnetic hex outputs available on AH3 models only.
Quick Change: Change AH3 to AHQ
1/4" Magnetic Hex: Change AH3 to AHM

Model Number		Torque Range		Free Speed	Length		Weight		Head Height		Side to Center		Air Consumption		
1/4" Sq. Dr.	3/8" Sq. Dr.	in.-lbs.	Nm	RPM	in.	mm	lbs.	kg	in.	mm	in.	mm	Air Inlet NPT	Min. Hose I.D.	SCFM
24 Series – Reversible – Clecomatic Clutch															
24RAA06AL3		3-4	4-5.5	2200	14.1	358	2.6	1.2	1.08	27.5	.47	12.0	3/8"	5/16"	24
24RAA07AL3		3-5	5-7	1770	14.1	358	2.6	1.2	1.08	27.5	.47	12.0	3/8"	5/16"	24
24RAA11AL3		5-8	7-11	1260	14.1	358	2.6	1.2	1.08	27.5	.47	12.0	3/8"	5/16"	24
24RAA12AM3		5-9	6-12	1200	14.2	360	2.8	1.3	1.16	29.5	.52	13.2	3/8"	5/16"	24
24RAA19AM3		7-14	10-19	700	15.0	380	3.2	1.4	1.16	29.5	.52	13.2	3/8"	5/16"	24
24RAA23AM3		9-17	12-23	600	15.0	380	3.2	1.4	1.16	29.5	.52	13.2	3/8"	5/16"	24
34 Series – Reversible – Clecomatic Clutch															
34RAA08AL3		4-6	8-5	2060	14.5	368	2.7	1.2	1.08	27.5	.47	12.0	3/8"	5/16"	34
34RAA11AL3		5-8	7-11	1675	14.5	368	2.7	1.2	1.08	27.5	.47	12.0	3/8"	5/16"	34
34RAA15AM3		7-11	9-15	1185	14.6	370	2.9	1.3	1.16	29.5	.52	13.2	3/8"	5/16"	34
34RAA26AH3		10-19	13-26	710	15.4	390	3.2	1.5	1.22	31.0	.57	14.4	3/8"	5/16"	34
34RAA28AH3		10-20	14-28	580	15.4	390	3.3	1.5	1.22	31.0	.57	14.4	3/8"	5/16"	34
34RAA33AX3		12-24	17-33	545	15.5	393	3.5	1.6	1.36	34.5	.67	17.1	3/8"	5/16"	34
34RAA37AX3		14-27	18-37	480	15.6	397	3.4	1.5	1.36	34.5	.67	17.1	3/8"	5/16"	34
34RAA47AX3		17-35	24-47	385	15.6	397	3.4	1.5	1.36	34.5	.67	17.1	3/8"	5/16"	34
34RAA68AZ3		25-50	34-68	255	16.2	411	3.7	1.7	1.60	41.0	.70	18.0	3/8"	5/16"	34
34RAA75AZ3		28-55	38-75	155	17.0	431	3.9	1.8	1.60	41.0	.70	18.0	3/8"	5/16"	34
	34RAA68AZ4	25-50	34-68	255	16.2	411	3.7	1.7	1.60	41.0	.70	18.0	3/8"	5/16"	34
	34RAA75AZ4	28-55	38-75	155	17.0	431	3.9	1.8	1.60	41.0	.70	18.0	3/8"	5/16"	34

General:

Tool performance rated at 90 psi (620kPa) air pressure.

Standard Equipment:

Operating instructions & service manual
Suspension bail
Exhaust Overhose
Clutch adjustment tool

Optional Equipment:

Assembly wrench: 201898
Torque signal kit: 201900
Non-reversible kit: 204999
Additional accessories: Page 46

Angle Nutrunners

45, 55 & 75 Series Clecomatic Clutch



45 Series

Torque Range:
28 – 115 Nm 21 – 85 Ft. Lbs.

- Button start
- Reversible & non-reversible
- External torque adjustment
- 1/2" square drive

55 Series

Torque Range:
32 – 176 Nm 24 – 130 Ft. Lbs.

- Lever start
- Reversible & non-reversible
- External torque adjustment
- Rotating exhaust deflector
- 1/2" square drive

75 Series

Torque Range:
95 – 430 Nm 70 – 320 Ft. Lbs.

- Lever start
- Reversible & non-reversible
- External torque adjustment
- Rotating exhaust deflector
- 1/2" & 3/4" square drive



45, 55 & 75 Model Number Example

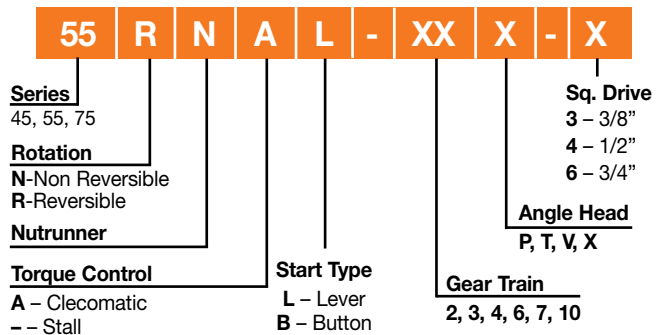

Model Number	Torque Range		Free Speed	Length		Weight		Head Height		Side to Center		Angle Head	Air Consumption		
	1/2" Sq. Dr.			RPM	in.	mm	lbs.	kg	in.	mm	in.		mm	Air Inlet NPT	Min. Hose I.D.
45 Series – Clecomatic Clutch – Button Start – Reversible															
45RNAB-4T-4	21 - 42	28 - 57	300	17.6	448	6.8	3.1	2.0	50	0.9	22	T	3/8"	3/8"	33
45RNAB-3P-4	26 - 52	35 - 71	240	17.5	445	6.4	2.9	1.6	41	0.7	18	P	3/8"	3/8"	33
45RNAB-3T-4	31 - 62	42 - 84	200	17.6	448	6.8	3.1	2.0	50	0.9	22	T	3/8"	3/8"	33
45RNAB-2P-4	34 - 71*	46 - 96*	180	17.5	445	6.4	2.9	1.6	41	0.7	18	P	3/8"	3/8"	33
45RNAB-2T-4	37 - 85	50 - 115	150	17.6	448	6.8	3.1	2.0	50	0.9	22	T	3/8"	3/8"	33
45 Series Clecomatic Clutch – Button Start – Non-Reversible															
45NAB-3P-4	28 - 57	38 - 77	300	17.5	445	6.3	2.8	1.6	41	0.7	18	P	3/8"	3/8"	33

* Maximum torque of tool exceeds the maximum torque rating for the head, high maintenance should be expected when operated at the upper torque capacity range.

General:
Tool performance rated at 90 psi (620kPa) air pressure.

Standard Equipment:
Operating instructions & service manual.
All torque springs required to meet indicated torque

Optional Equipment:
Additional accessories: Page 46

Model Number	Torque Range		Free Speed	Length		Weight		Head Height		Side to Center		Angle Head	Air Consumption		
	1/2" Sq. Dr.	3/4" Sq. Dr.		RPM	in.	mm	lbs.	kg	in.	mm	in.		mm	Air Inlet NPT	Min. Hose I.D.
55 & 75 Series – Lever Start – Reversible															
55RNAL-6T-4	24 - 48	32 - 65	370	19.3	489	7.8	3.5	2.0	50	0.9	22	T	1/2"	1/2"	55
55RNAL-4P-4	26 - 54	35 - 73	330	19.1	486	7.4	3.3	1.6	41	0.7	18	P	1/2"	1/2"	55
55RNAL-4T-4	29 - 64	39 - 87	280	19.3	489	7.8	3.5	2.0	50	0.9	22	T	1/2"	1/2"	55
55RNAL-3P-4	36 - 80*	49 - 109*	220	19.1	486	7.4	3.3	1.6	41	0.7	18	P	1/2"	1/2"	55
55RNAL-3T-4	43 - 95	58 - 129	190	19.3	489	7.8	3.5	2.0	50	0.9	22	T	1/2"	1/2"	55
55RNAL-2T-4	60 - 125*	81 - 170*	140	19.3	489	7.8	3.5	2.0	50	0.9	22	T	1/2"	1/2"	55
75RNAL-3V-4	70 - 140	95 - 190	175	21.9	556	13.3	6.0	2.5	64	1.1	28	V	1/2"	1/2"	70
75RNAL-2V-4	90 - 190*	122 - 255*	130	21.9	556	13.3	6.0	2.5	64	1.1	28	V	1/2"	1/2"	70
75RNAL-3X-6	110 - 225	150 - 305	110	22.6	575	15.0	6.8	2.8	70	1.4	37	X	1/2"	1/2"	70
75RNAL-2X-6	150 - 305	203 - 410	80	22.6	575	15.0	6.8	2.8	70	1.4	37	X	1/2"	1/2"	70
55 & 75 Series – Lever Start – Non-Reversible															
55NAL-4P-4	28 - 57	28 - 77	480	19.1	486	7.3	3.3	1.6	41	72.0	18	P	1/2"	1/2"	55
55NAL-4T-4	33 - 69	39 - 93	400	19.3	489	7.6	3.5	2.0	50	0.9	22	T	1/2"	1/2"	55
55NAL-3P-4	39 - 84*	49 - 114*	320	19.1	486	7.3	3.3	1.6	41	72.0	18	P	1/2"	1/2"	55
55NAL-3T-4	45 - 100	58 - 136	270	19.3	489	7.6	3.5	2.0	50	0.9	22	T	1/2"	1/2"	55
55NAL-2T-4	55 - 130*	68 - 176*	200	19.3	489	7.6	3.5	2.0	50	0.9	22	T	1/2"	1/2"	55
75NAL-2V-4	100 - 200	135 - 271	210	21.9	556	13.0	5.9	2.5	64	1.1	28	V	1/2"	1/2"	70
75NAL-2X-6	160 - 320	215 - 430	130	22.6	575	14.8	6.7	2.8	70	1.4	37	X	1/2"	1/2"	70

* Maximum torque of tool exceeds the maximum torque rating for the head, high maintenance should be expected when operated at the upper torque capacity range.

Standard Equipment:
Operating instructions & service manual
Torque Reaction Mounting Plate (75 series)
All torque springs required to meet indicated torque

Optional Equipment:
Additional accessories: Page 46

General:
Tool performance rated at 90 psi (620kPa) air pressure.

Angle Nutrunners

14, 24, 34, 45 & 75 Series Stall – Reversible & Non-Reversible

Cleco®

14 Series Reversible

Torque Range:

3.2 – 6.2 Nm 2.3 – 4.6 Ft. Lbs.

- Lever start
- Sliding knob reverse

24 Series Reversible

Torque Range:

13 Nm 9.6 Ft. Lbs.

- Lever start
- Twist ring reverse

34 Series Reversible

Torque Range:

11 - 36 Nm 8.1 - 26 Ft. Lbs.

- Lever start
- Twist ring reverse

45 Series Reversible

Torque Range:

62 - 125 Nm 46 - 92 Ft. Lbs.

- Button start
- Twist ring reverse

55 Series Reversible & Non-Reversible

Torque Range:

56 - 203 Nm 41 - 150 Ft. Lbs.

- Lever start
- Reversible & non-reversible

75 Series Reversible & Non-Reversible

Torque Range:

210 - 475 Nm 155 - 350 Ft. Lbs.

- Lever start
- Reversible & non-reversible



Model Number	Max. Torque		Square Drive	Free Speed	Length		Weight		Head Height		Side to Center		Air Consumption		
	ft.-lbs.	Nm			in.	RPM	in.	mm	lbs.	kg	in.	mm	in.	mm	Air Inlet NPT

14 Series – Reversible – Stall

14RAS03AM2	2.3	3.2	1/4	1700	11.4	289	1.3	0.6	1.1	27	0.4	9	1/8"	3/16"	11
14RAS04AH2	2.7*	3.6*	1/4	1250	11.2	284	1.4	0.6	1.2	30	0.5	13	1/8"	3/16"	11
14RAS05AM2	3.8	5.2	1/4	850	10.6	268	1.2	0.5	1.1	27	0.4	9	1/8"	3/16"	11
14RAS06AH3	4.6	6.2	3/8	880	11.0	279	1.3	0.6	1.2	30	0.5	13	1/8"	3/16"	11

45 Series – Reversible – Stall

45RNB-4T-4	46	62	1/2	310	15.1	384	5.5	2.5	2.0	50	0.9	22	3/8"	3/8"	33
45RNB-3P-4	58	79	1/2	250	15.0	381	5.1	2.3	1.6	41	0.7	18	3/8"	3/8"	33
45RNB-3T-4	69	94	1/2	210	15.1	384	5.5	2.5	2.0	50	0.9	22	3/8"	3/8"	33
45RNB-2T-4	92	125	1/2	160	15.1	384	5.5	2.5	2.0	50	0.9	22	3/8"	3/8"	33

24, 34, 55 & 75 Series – Reversible – Stall

34RAS11AL3	8.1	11	3/8	1675	12.0	305	2.1	1.0	1.1	28	0.5	12	3/8"	5/16"	34
24RAS13AM3	9.6	13	3/8	1200	11.7	297	2.2	1.0	1.2	30	0.5	13	3/8"	5/16"	24
34RAS28AH3	20	28	3/8	710	12.9	328	2.6	1.2	1.2	31	0.6	14	3/8"	5/16"	34
34RAS36AX3	26	36	3/8	545	13.0	330	2.8	1.3	1.4	35	0.7	17	3/8"	5/16"	34
55RNL-7T-4	41	56	1/2	490	16.1	410	6.1	2.8	2.0	50	0.9	22	1/2"	1/2"	55
55RNL-3T-4	100*	136*	1/2	195	16.8	425	6.5	2.9	2.0	50	0.9	22	1/2"	1/2"	55
55RNL-2T-4	130*	176*	1/2	145	16.8	425	6.5	2.9	2.0	50	0.9	22	1/2"	1/2"	55
75RNL-3V-4	155	210	1/2	190	19.4	492	11.4	5.2	2.5	64	1.1	28	1/2"	1/2"	70
75RNL-3X-6	245	330	3/4	120	20.1	511	13.1	6.0	2.8	70	1.4	37	1/2"	1/2"	70
75RNL-2X-6	325	440	3/4	90	20.1	511	13.1	6.0	2.8	70	1.4	37	1/2"	1/2"	70

* Maximum torque of tool exceeds the maximum torque rating for the head, high maintenance should be expected when operated at the upper torque capacity range.

General:
Tool performance rated at 90 psi (620kPa) air pressure.

Standard Equipment:
Operating instructions & service manual
Suspension bail (14 series)
Torque reaction mounting plate (75 series)

Optional Equipment:
14 Series: Non-Reverse Kit: 207030
Overhose: 207019

Quick Change and 1/4" magnetic hex outputs available on AH3 models only.
Quick Change: Change AH3 to AHQ
1/4" Magnetic Hex: Change AH3 to AHM
24/34 Series: Assembly wrench:
Non-reverse kit
Additional accessories: Page 46

201898
204999

Model Number	Max. Torque		Square Drive	Free Speed	Length		Weight		Head Height		Side to Center		Air Consumption		
	ft.-lbs.	Nm			in.	RPM	in.	mm	lbs.	kg	in.	mm	in.	mm	Air Inlet NPT

55 & 75 Series Non-Reversible – Stall

55NL-3T-4	110*	149*	1/2	290	16.8	425	6.4	2.9	2.0	50	0.9	22	1/2"	1/2"	55
55NL-2T-4	150*	203*	1/2	210	16.8	425	6.4	2.9	2.0	50	0.9	22	1/2"	1/2"	55
75NL-3V-4	165	225	1/2	300	19.4	492	11.1	5.0	2.5	64	1.1	28	1/2"	1/2"	70
75NL-2V-4	220*	298*	1/2	230	19.4	492	11.1	5.0	2.5	64	1.1	28	1/2"	1/2"	70
75NL-2X-6	350	475	3/4	140	20.1	511	12.9	5.8	2.8	70	1.4	37	1/2"	1/2"	70

* Maximum torque of tool exceeds the maximum torque rating for the head, high maintenance should be expected when operated at the upper torque capacity range.

General:
Tool performance rated at 90 psi (620kPa) air pressure

Standard Equipment:
Operating instructions & service manual
Torque Reaction Mounting Plate (75 series)

Optional Equipment:
Additional accessories: Page 46
Safety Lever: 201638

14, 24, & 34 Model Number Example

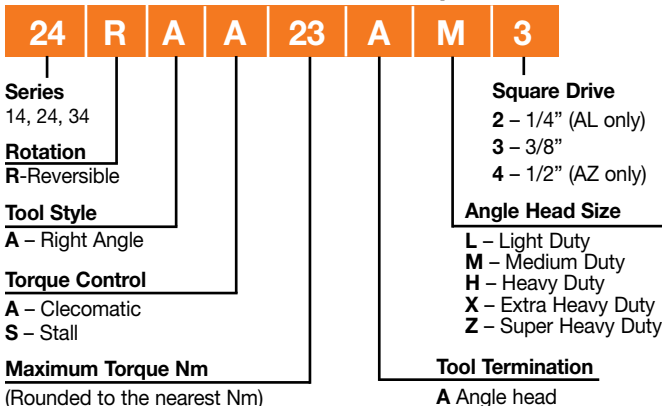

45, 55 & 75 Model Number Example

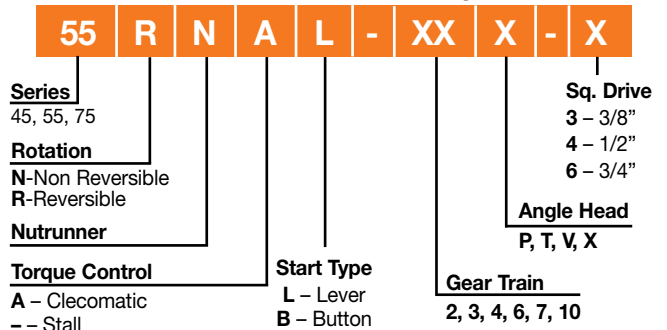

Swingbar Nutrunners

Cleco®

Smaller, Faster, Lighter

For high torque applications where a small tool is necessary, for consistency in clamp load across joint types or for simply eliminating the maintenance needs of an angle tool, the Cleco 64 Series provides the best solution for today's heavy assembly environment.

Benefits of a Swingbar Tool

A swingbar tool includes a reaction bar that freely swings 360°. This allows the reaction bar to be moved to an appropriate bracing point without any disassembly or repositioning of a spline. Once positioned, the reaction bar absorbs the reaction forces of the tool.

Selectork

Output torque from a stall tool is achieved by adjusting the air pressure to the tool. If the tool is

moved from location to location or if other tools requiring full line pressure use the same air line, the tool will require a dedicated air pressure regulator.

The Cleco Selectork feature in the 64 Series tools is a small pressure regulator that takes the place of the standard air inlet bushing and eliminates the need to have a separate pressure regulator installed in the plant floor system. Because of the small size of the Selectork there is a limited pressure adjustment range of from 60 to 90 psi. To order this option on the Cleco 64TTS Swingbar tools replace the "S" in the model number with a "K" (64TTS...to a 64TTK...).

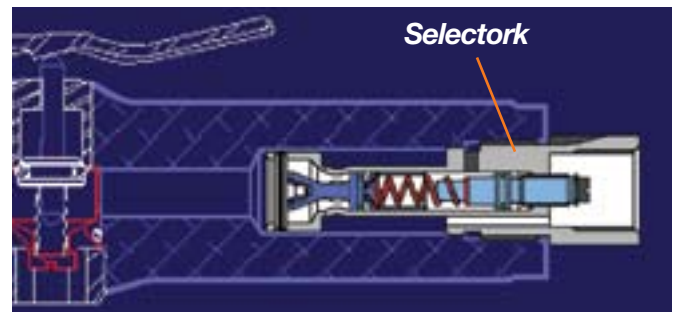

Reversible

A simple to use and convenient slide reverse lever improves productivity by allowing for the loosening of fasteners without changing tools.



Improved Ergonomics

Top and bottom air inlets help customize the 64 Series Reaction Bar Nutrunners to the operator's work area.

Improved Ergonomics

Comfort molded handles and lighter weights reduce operator fatigue and improve productivity

Selectork

for optimal in-tool air pressure regulation.

Ergonomics

Infinite-position reaction bar can quickly be moved to an appropriate brace point, eliminating reaction forces of the rundown.





Speed and Torque Tests for the Cleco 64 Series Swingbar Nutrunners

The goal of any fastening application is to maintain a high degree of accuracy while minimizing the length of time required to perform the rundown. The Cleco 64 Series Swingbar Nutrunners utilize a single powerful motor that limits speed shifts and offers a fast and accurate rundown regardless of joint type.

Competitive units with high RPM's quickly drop their speed at threshold resulting in an overall longer rundown period. This gap is multiplied when prevailing torque is present.

To read the graphs below, the orange line represents the tool speed while the blue line represents the torque generated throughout a rundown. Notice the correlation between speed and torque and its overall effect on rundown time.

The swingbar can instantly be positioned to absorb the torque reaction of the tool while maintaining a comfortable position with the trigger hand.

Random Comparison on 120° Joint

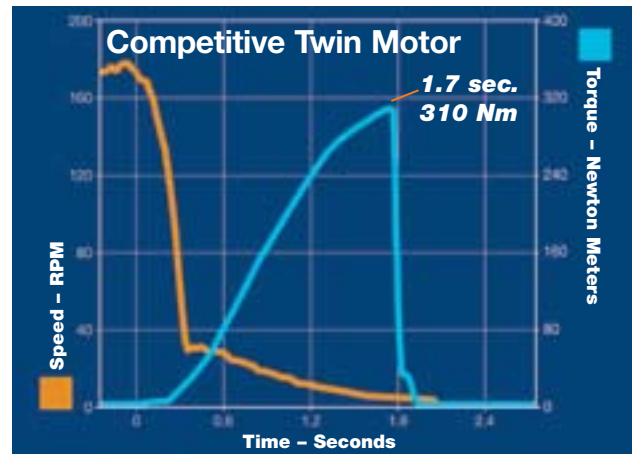
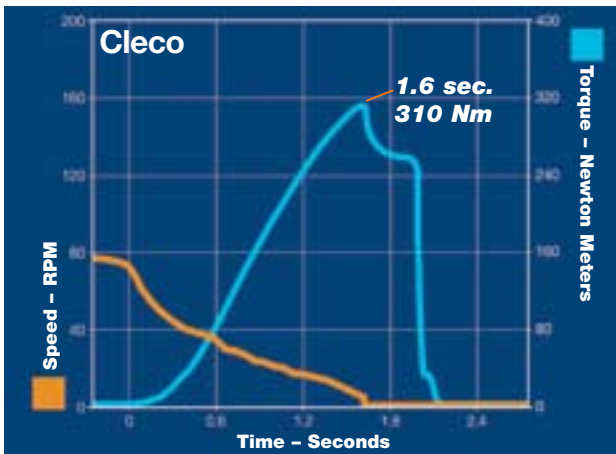

Random Comparison on 720° Joint

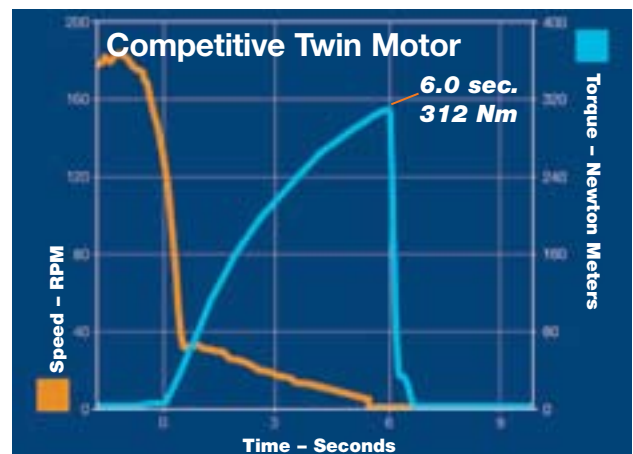
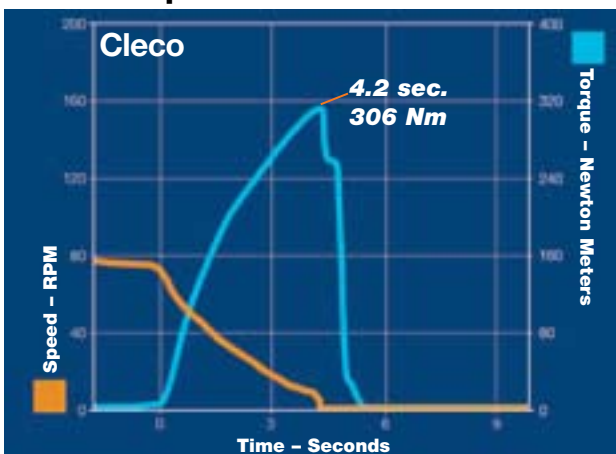

Again the free speed of the Cleco tool is slower, however with its faster tightening speed the overall time is almost 2 seconds faster.

Reaction Bar & Swingbar Nutrunners



45 Series Inline

Torque Range:
14 - 62 Nm 10 - 46 Ft. Lbs.

- Button start
- Twist ring reverse



55 Series Inline

Torque Range:
27 - 91 Nm 20 - 67 Ft. Lbs.

- Lever start
- Twist ring reverse



64 Series Pistol

Torque Range:
34 - 3850 Nm 25 - 2837 Ft. Lbs.

- Trigger start
- Sliding knob reverse
- Swingbar



Selectork 64 Series

Torque Range:
26 - 3850 Nm 19 - 2837 Ft. Lbs.

- Pistol grip
- Reversible
- Swingbar
- Selectork adjustment allows air pressure regulation at the tool for individual performance from a common air line



45 & 55 Model Number Example

55 R N A L - X - X

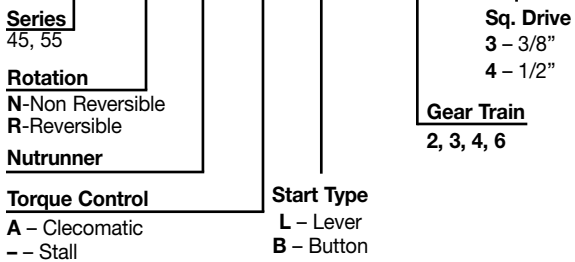

64 Model Number Example

64 T T S XX D X

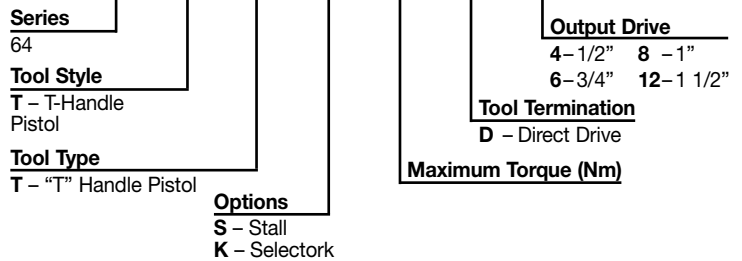

Reaction Bar & Swingbar Nutrunners



Model Number	Torque Range		Drive Size	Free Speed RPM	Length		Weight*		Air Consumption			
	ft.-lbs.	Nm			in.	mm	lbs.	kg	Air Inlet NPT	Min. Hose I.D.	SCFM	
45 Series – Inline – Clecomatic – Button Start – Twist Ring Reverse												
45RNAB-6-3	10 - 16	14 - 22	3/8	740	14.5	368	5.4	2.4	3/8"	3/8"	33	
45RNAB-4-3	14 - 22	19 - 30	3/8	560	14.5	368	5.4	2.4	3/8"	3/8"	33	
45RNAB-3-3	18 - 33	24 - 45	3/8	370	14.5	368	5.4	2.4	3/8"	3/8"	33	
45RNAB-2-4	23 - 46	31 - 62	1/2	270	14.5	368	5.4	2.4	3/8"	3/8"	33	
55 Series – Inline – Clecomatic – Lever Start – Twist Ring Reverse												
55RNAL-4-4	20 - 34	27 - 46	1/2	560	16.1	410	6.5	3.0	1/2"	1/2"	55	
55RNAL-3-4	25 - 51	34 - 69	1/2	370	16.1	410	6.5	3.0	1/2"	1/2"	55	
55RNAL-2-4	30 - 67	46 - 91	1/2	270	16.1	410	6.5	3.0	1/2"	1/2"	55	

* Weight without reaction bar.

General:

Tool performance rated at 90 psi (620kPa) air pressure

Standard Equipment:

Operating instructions & service manual
Aluminum Torque Reaction Bar

Optional Equipment:

Steel Torque Reaction Bar: 869770
Additional accessories: Page 46

Model Number		Torque Range		Drive Size	Free Speed RPM	Length		Weight*		Air Consumption		
Non-Selectork	Selectork	ft.-lbs.	Nm			in.	mm	lbs.	kg	Air Inlet NPT	Min. Hose I.D.	SCFM
Pistol – Trigger Start – Reversible												
64TTS34D4	64TTK34D4	19 - 25	26 - 34	1/2"	725	11.5	290.8	6.3	2.9	3/8"	1/2"	60
64TTS44D4	64TTK44D4	24 - 32	33 - 44	1/2"	570	11.5	290.8	6.3	2.9	3/8"	1/2"	60
64TTS55D4	64TTK55D4	30 - 41	41 - 55	1/2"	445	11.5	290.8	6.3	2.9	3/8"	1/2"	60
64TTS75D4	64TTK75D4	41 - 55	56 - 75	1/2"	340	11.5	290.8	6.3	2.9	3/8"	1/2"	60
64TTS90D4	64TTK90D4	50 - 66	68 - 90	1/2"	270	11.5	290.8	6.3	2.9	3/8"	1/2"	60
64TTS110D4	64TTK110D4	61 - 81	83 - 110	1/2"	225	11.5	290.8	6.3	2.9	3/8"	1/2"	60
64TTS125D4	64TTK125D4	69 - 92	94 - 125	1/2"	200	11.5	290.8	6.3	2.9	3/8"	1/2"	60
64TTS140D4	64TTK140D4	77 - 103	105 - 140	1/2"	180	11.5	290.8	6.3	2.9	3/8"	1/2"	60
64TTS150D6	64TTK150D6	83 - 111	113 - 150	3/4"	160	12.5	316.2	8.2	3.7	3/8"	1/2"	60
64TTS175D6	64TTK175D6	97 - 129	131 - 175	3/4"	135	12.5	316.2	8.2	3.7	3/8"	1/2"	60
64TTS205D6	64TTK205D6	113 - 151	154 - 205	3/4"	115	12.5	316.2	8.2	3.7	3/8"	1/2"	60
64TTS255D6	64TTK255D6	141 - 188	191 - 255	3/4"	95	12.5	316.2	8.2	3.7	3/8"	1/2"	60
64TTS345D6	64TTK345D6	191 - 254	259 - 345	3/4"	70	12.5	316.2	8.2	3.7	3/8"	1/2"	60
64TTS425D6	64TTK425D6	235 - 313	319 - 425	3/4"	55	12.5	316.2	8.2	3.7	3/8"	1/2"	60
64TTS570D6	64TTK570D6	315 - 420	428 - 570	3/4"	42	13.0	328.9	8.6	3.9	3/8"	1/2"	60
64TTS640D8	64TTK640D8	354 - 472	480 - 640	1"	32	15.9	404.1	14.5	6.6	3/8"	1/2"	60
64TTS750D8	64TTK750D8	415 - 553	563 - 750	1"	27	15.9	404.1	14.5	6.6	3/8"	1/2"	60
64TTS930D8	64TTK930D8	514 - 686	698 - 930	1"	22	15.9	404.1	14.5	6.6	3/8"	1/2"	60
64TTS1260D8	64TTK1260D8	697 - 929	945 - 1260	1"	16	15.9	404.1	14.5	6.6	3/8"	1/2"	60
64TTS1475D8	64TTK1475D8	816 - 1088	1106 - 1475	1"	14	15.9	404.1	14.5	6.6	3/8"	1/2"	60
64TTS1820D8	64TTK1820D8	1007 - 1342	1365 - 1820	1"	11	15.9	404.1	14.5	6.6	3/8"	1/2"	60
64TTS1985D8	64TTK1985D8	1098 - 1464	1489 - 1985	1"	10	15.9	404.1	14.5	6.6	3/8"	1/2"	60
64TTS3850D12	64TTK3850D12	2128 - 2837	2888 - 3850	1 1/2"	5	21.5	546.1	32.2	14.6	3/8"	1/2"	60

* Weight without reaction bar.

General:

Tool performance rated at 90 psi (620kPa) air pressure.

Standard Equipment:

Operating instructions & service manual
Aluminum Torque Reaction Bar
Steel Torque Reaction Bar (tools rated above 50 ft. lbs.)
Slave Square Drive (64TTS3850D12 & 64TTK3850D12)

Optional Equipment:

Steel Torque Reaction Bar: 64.....D4 series: 48047128
Additional accessories: Page 46

Flush Socket Nutrunners

Clecomatic Clutch & StallStall



34 Series

Torque Range:

5 – 103 Nm 4 – 76 Ft. Lbs

- External torque adjustment (Clecomatic models)
- Indexable anglehead
- One torque spring to meet specified range
- Oilless blades
- Reversible 



X Dimension For Flush Socket

Head	Inches	Millimeters	Socket Size Range
F1	1.54	39	8–15mm
F2	1.69	43	10–15mm
F3	2.32	59	13–21mm

NOTE: Models listed are examples. Use chart on bottom of facing page for specific model required but not listed.

Model Number	Free Speed RPM	Torque		Length		Weight		Anglehead				Air Consumption		
		ft.-lbs.	Nm	in.	mm	lbs.	kg	Height in.	mm	Side to Center in.	mm	Air Inlet NPT	Min. Hose I.D.	SCFM
Clecomatic - Lever Start - Reversible														
34RAA09F1	1825	4-7	5-9	17.0	432	3.7	1.7	1.54	39	0.55	14	3/8"	5/16"	34
34RAA16F1	1055	7-12	9-16	17.0	432	3.7	1.7	1.54	39	0.55	14	3/8"	5/16"	34
34RAA28F1	645	10-20*	14-28*	17.8	452	3.9	1.8	1.54	39	0.55	14	3/8"	5/16"	34
34RAA33F2	540	12-24	17-33	18.8	478	4.7	2.1	1.69	43	0.67	17	3/8"	5/16"	34
34RAA47F2	380	17-35	24-47	19.0	483	5.1	2.3	1.69	43	0.67	17	3/8"	5/16"	34
34RAA53F2	265	17-39	24-53	19.0	483	5.1	2.3	1.69	43	0.67	17	3/8"	5/16"	34
34RAA67F3	265	24-49	33-67	20.5	521	5.8	2.6	2.32	59	0.87	22	3/8"	5/16"	34
34RAA94F3	185	35-69	47-94	20.5	521	5.8	2.6	2.32	59	0.87	22	3/8"	5/16"	34
Stall - Lever Start - Reversible														
34RAS10F1	1825	7	10	17.0	432	3.4	1.5	1.54	39	0.55	14	3/8"	5/16"	34
34RAS18F1	1055	13	18	17.0	432	3.4	1.5	1.54	39	0.55	14	3/8"	5/16"	34
34RAS30F1	645	22*	30*	17.8	452	3.5	1.6	1.54	39	0.55	14	3/8"	5/16"	34
34RAS40F2	480	29	40	19.0	483	4.4	2.0	1.69	43	0.67	17	3/8"	5/16"	34
34RAS52F2	380	38	52	19.0	483	4.4	2.0	1.69	43	0.67	17	3/8"	5/16"	34
34RAS58F3	335	43	58	20.5	521	5.5	2.5	2.32	59	0.87	22	3/8"	5/16"	34
34RAS73F3	265	54	73	20.5	521	5.5	2.5	2.32	59	0.87	22	3/8"	5/16"	34
34RAS103F3	185	76	103	20.5	521	5.5	2.5	2.32	59	0.87	22	3/8"	5/16"	34

* Maximum torque of tool exceeds the maximum torque rating for the head, high maintenance should be expected when operated at the upper torque capacity range.

General:

Tool performance rated at 90 psi (620kPa) air pressure.

Standard Equipment:

Operating instructions & service manual
Suspension bail
Exhaust Overhose
Clutch adjustment tool (Clecomatic tools)
Mounting plate (F3 tools)

Optional Equipment:

Assembly wrench: 201898
Torque signal kit: 201900
Non-reversible kit: 204999
Mounting plates: F1 tools 57217101 57218103
F2 tools 43287131

Additional accessories: Page 46



Tight clearance applications, once only accessible by the use of hand tools or crowfoot attachments, can now be tightened by the family of Cleco Flush Socket Pneumatic Tools at a speed that maximizes productivity. Tools equipped with a Clecomatic clutch assure good torque repeatability.

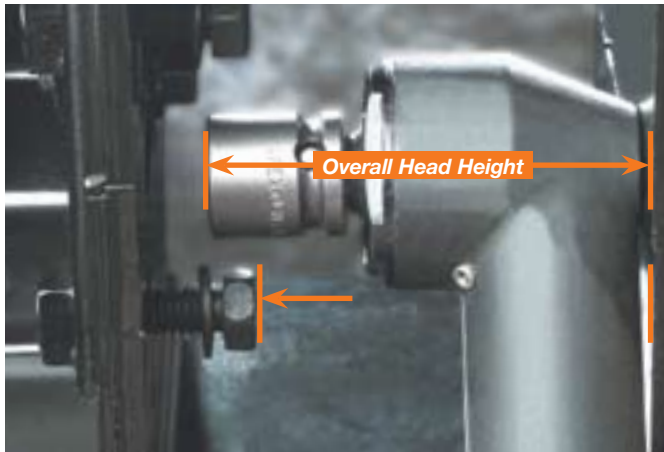

Standard right angle head with square drive and separate socket will not fit on tight clearance applications. The overall head height is greater than the available clearance.

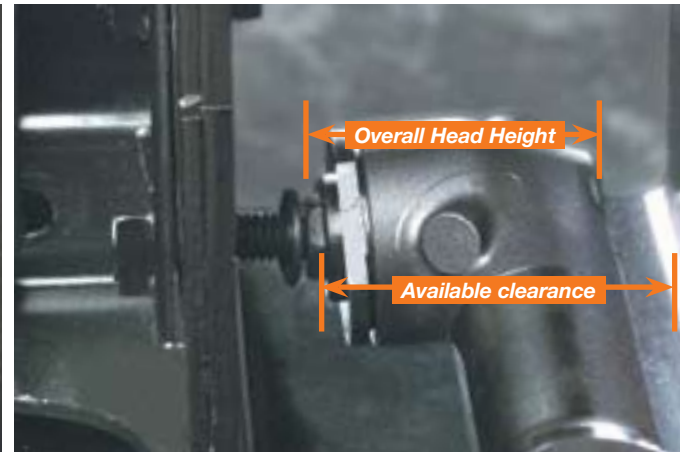

Flush socket tools have plenty of clearance to fit on the same application. Clecomatic flush socket tools tighten with much higher accuracy than tools with crowfoot attachment. The overall head height is less than the available clearance.

Model Number Example

Base Tool

34 R A A 16 F1

Motor

Reversible

Tool Style

A - Angle

Control

A - Clutch
S - Stall

Maximum Torque Output

F1 Clutch: 9, 16, 28 Nm
Stall: 10, 18, 30 Nm

F2 Clutch: 33, 47, 53 Nm
Stall: 40, 52 Nm

F3 Clutch: 67, 94 Nm
Stall: 58, 73, 103 Nm

Flush Socket Head

F1 Head: 8-15 mm socket capacity
F2 Head: 10-15 mm socket capacity
F3 Head: 13-21 mm socket capacity

Socket No. (ordered with base tool)

FS 1 MG 0 0

Flush Socket Head

1 - F1 Head
2 - F2 Head
3 - F3 Head

Socket Type

FS - Flush

Output Type

1-Thru Hex

Extension Length

0 - Flush 4 - 1/2" 6 - 3/4"

Socket Sizes

EA - 1/4"	MA - 7mm
EC - 3/8"	MB - 8mm
ED - 7/16"	MC - 9mm
EE - 1/2"	MD - 10mm
EF - 9/16"	ME - 11mm
	MF - 12mm
	MG - 13mm
	MH - 14mm
	MI - 15mm

Note: When ordering, specify the base tool and order the socket separately. The socket will be installed in the tool before shipment.

Crowfoot Nutrunners

Clecomatic Clutch & Stall

Cleco®

34 Series

Torque Range:

14 – 30 Nm

10 – 22 Ft. Lbs

- External torque adjustment (Clecomatic models)
- Indexable anglehead
- One torque spring to meet specified range
- Oilless blades
- Reversible 



NOTE: Models listed are examples. Use chart on bottom of facing page for specific model required but not listed.

Model Number		Free Speed	Torque Range		Socket Size		Length		Weight		Air Consumption		
15 Degree Head	30 Degree Head	RPM	ft.-lbs.	Nm	in.	mm	in.	mm	lbs.	kg	NPT	I.D.	SCFM
Clecomatic - Lever Start - Reversible													
34RCA30D1	34RCA30D3	425	11-22	15-30	5/16	8	20.0	507	4.7	2.2	3/8"	5/16"	34
Stall - Lever Start - Reversible													
34RCS29D1	34RCS29D3	490	21	29	5/16	8	19.6	497	4.5	2.1	3/8"	5/16"	34

General:

Tool performance rated at 90 psi (620kPa) air pressure.

Standard Equipment:

Operating instructions & service manual
 Suspension bail
 Exhaust Overhose
 Clutch adjustment tool (Clecomatic tools)

Extra Equipment:

Specify socket from page 41.

Optional Equipment:

Assembly wrench: 201898
 Torque signal kit: 201900
 Non-reversible kit: 204999
 Additional accessories: Page 46

15° Head

Part Number: 301071

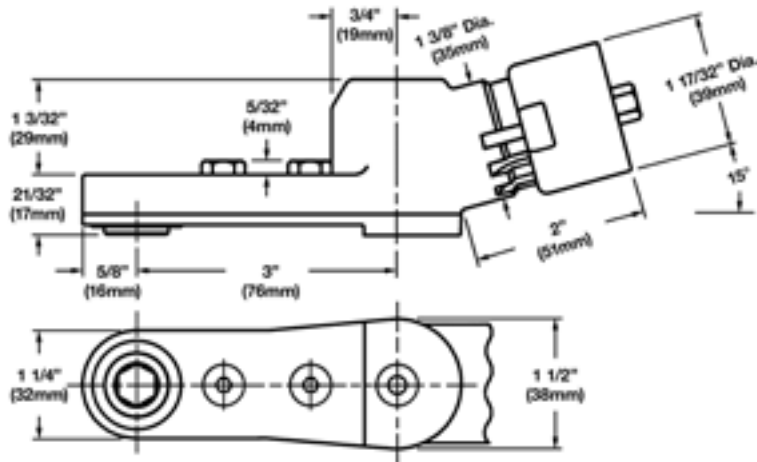

30° Head

Part Number: 301072

Maximum Recommended

Torque: 22 ft. lbs. (30 Nm)

Standard Length Socket

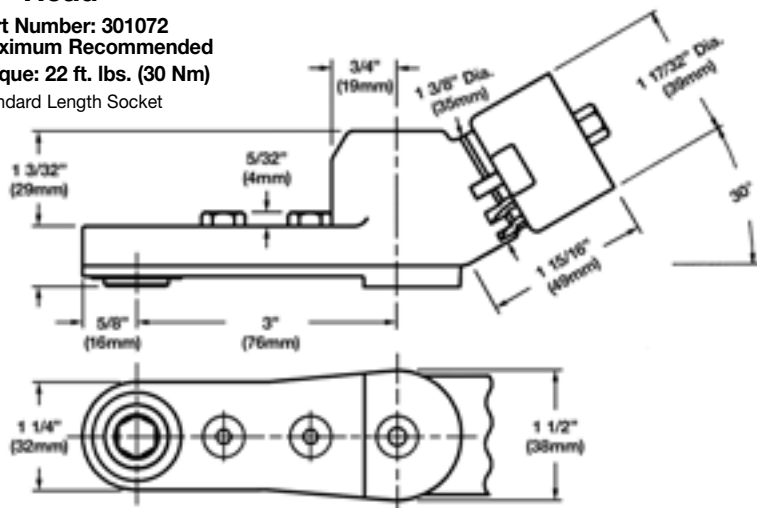

Model Number Example

Base Tool

34 R C A 30 D1

Motor
34

Rotation
R - Reversible

Tool Style
C - Crowfoot

Control

A - Clecomatic
S - Stall

Max Output Torque

Clecomatic: 30
Stall: 14, 29

Tool Termination

D1 15° Head
D3 30° Head

Socket No. (ordered with base tool)

CS XX X X

Crowfoot Socket

Output Type

1 - Thru Hex

Extension Length

0 - Flush 4 - 1/2" 6 - 3/4"

Sockets

Flush		1/2" Extended	3/4" Extended
EA - 1/4"	MD - 10mm	EB - 5/16"	EE - 1/2"
EC - 3/8"	ME - 11mm	EC - 3/8"	MG - 13mm
ED - 7/16"	MF - 12mm	ED - 7/16"	MH - 14mm
EE - 1/2"	MG - 13mm	EE - 1/2"	
EF - 9/16"	MH - 14mm	EF - 9/16"	
MB - 8mm	MI - 15mm	MB - 8mm	
EH - 11/16"		MD - 10mm	
		ME - 11mm	
		MF - 12mm	
		MG - 13mm	

Hold & Drive Nutrunners

Clecomatic Clutch & Stall

Cleco®

34 Series

Torque Range:

24 – 103 Nm 17 – 76 Ft. Lbs

- External torque adjustment (Clecomatic models)
- Indexable anglehead
- One torque spring to meet specified range
- 1" retraction of hold spindle
- Oilless blades
- Reversible 

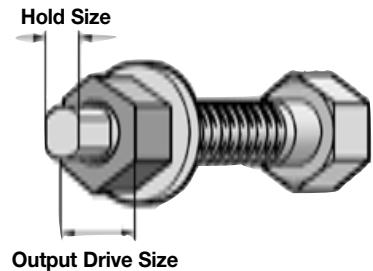

NOTE: Models listed are examples. Use chart on bottom of facing page for specific model required but not listed.

Model Number	Hold Size	Free Speed RPM	Torque		Length		Weight		Anglehead				Air Consumption		
			ft.-lbs.	Nm	in.	mm	lbs.	kg	Height		Side to Center		NPT	Hose I.D.	SCFM
									in.	mm	in.	mm			
Clecomatic - Lever Start - Reversible															
34RAA53H3	5mm Female Hex	335	17-39	24-53	20.7	526	8.0	3.5	2.4	61	1.06	27	3/8"	5/16"	34
34RAA67H3	7mm Female Hex	265	24-49	33-67	20.7	526	8.0	3.5	2.4	61	1.06	27	3/8"	5/16"	34
34RAA94H3	8mm Female Hex	185	35-69	47-94	20.7	526	8.0	3.5	2.4	61	1.06	27	3/8"	5/16"	34
Stall - Lever Start - Reversible															
34RAS58H3	5mm Female Hex	335	43	58	20.7	526	7.7	3.5	2.4	61	1.06	27	3/8"	5/16"	34
34RAS73H3	T30 Torx	265	54	73	20.7	526	7.7	3.5	2.4	61	1.06	27	3/8"	5/16"	34
34RAS103H3	10mm Female Hex	185	76	103	20.7	526	7.7	3.5	2.4	61	1.06	27	3/8"	5/16"	34

General:

Tool performance rated at 90 psi (620kPa) air pressure.

Standard Equipment:

Operating instructions & service manual
 Suspension bail
 Exhaust Overhose
 Clutch adjustment tool (Clecomatic tools)
 Mounting Plate

Optional Equipment:

Assembly wrench: 201898
 Torque signal kit: 201900
 Non-reversible kit: 204999
 Additional accessories: Page 46

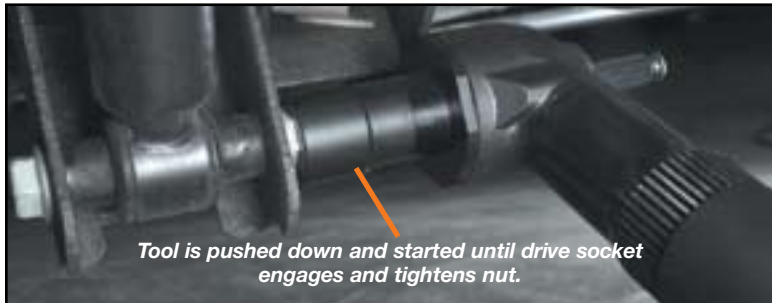
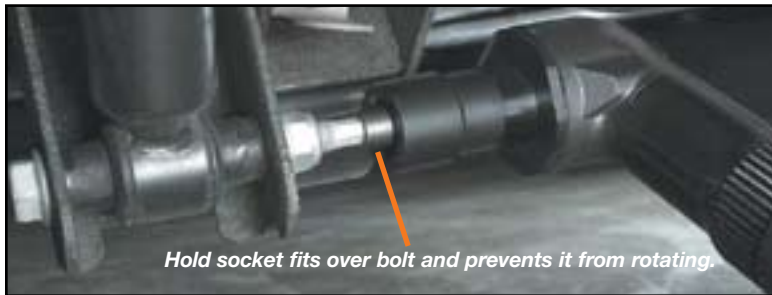

“Hold & Drive” bolts are used with these tools in automotive and truck frame applications. They reduce assembly handling to one person working from one side of the workpiece. The bolt is held stationary by the tool while the nut is tightened from the same side. This also eliminates reaction bars since the bolt absorbs the torque.

Model Number Example

Base Tool						Drive Socket		Hold Socket																																	
34	R	A	A	53	H	3	HD	ML	O	M6	B																														
Motor	Reversible		Tool Style A – Angle		Control A – Clutch S – Stall		Hold & Drive Socket	Oval Length (for oval only) <i>(Example: For a 6mm x 8mm oval, this dimension would be MB, but drop the “M” as in M6B.)</i>																																	
Maximum Torque Output Clutch: 53, 67, 94 Nm Stall: 58, 73, 103 Nm						Hold Socket (dimension across flats, oval also)																																			
Tool Termination H – Hold & Drive						<table border="0"> <tr> <td>EA – 1/4"</td> <td>M6 – 6mm</td> <td>MH – 14mm</td> </tr> <tr> <td>EB – 5/16"</td> <td>MA – 7mm</td> <td>15 – T15</td> </tr> <tr> <td>EC – 3/8"</td> <td>MB – 8mm</td> <td>20 – T20</td> </tr> <tr> <td>ED – 7/16"</td> <td>MC – 9mm</td> <td>25 – T25</td> </tr> <tr> <td>EE – 1/2"</td> <td>MD – 10mm</td> <td>30 – T30</td> </tr> <tr> <td>EF – 9/16"</td> <td>ME – 11mm</td> <td>40 – T40</td> </tr> <tr> <td>EG – 5/8"</td> <td>MF – 12mm</td> <td>45 – T45</td> </tr> <tr> <td>M5 – 5mm</td> <td>MG – 13mm</td> <td></td> </tr> </table>						EA – 1/4"	M6 – 6mm	MH – 14mm	EB – 5/16"	MA – 7mm	15 – T15	EC – 3/8"	MB – 8mm	20 – T20	ED – 7/16"	MC – 9mm	25 – T25	EE – 1/2"	MD – 10mm	30 – T30	EF – 9/16"	ME – 11mm	40 – T40	EG – 5/8"	MF – 12mm	45 – T45	M5 – 5mm	MG – 13mm							
EA – 1/4"	M6 – 6mm	MH – 14mm																																							
EB – 5/16"	MA – 7mm	15 – T15																																							
EC – 3/8"	MB – 8mm	20 – T20																																							
ED – 7/16"	MC – 9mm	25 – T25																																							
EE – 1/2"	MD – 10mm	30 – T30																																							
EF – 9/16"	ME – 11mm	40 – T40																																							
EG – 5/8"	MF – 12mm	45 – T45																																							
M5 – 5mm	MG – 13mm																																								
Retainer Shaft Length 3 – 3 1/2" 4 – 4" 5 – 5 3/8" 6 – 5 7/8" 9 – 9"						Hold Socket Style F – Female Hex T – Torx M – Male Hex O – Female oval																																			
Drive Socket Size						Drive Socket Size																																			
<table border="0"> <tr> <td>EE – 1/2"</td> <td>EK – 7/8"</td> <td>EQ – 1 1/4"</td> <td>ML – 18mm</td> <td>MR – 24mm</td> </tr> <tr> <td>EF – 9/16"</td> <td>EL – 15/16"</td> <td>MG – 13mm</td> <td>MM – 19mm</td> <td>MS – 25mm</td> </tr> <tr> <td>EG – 5/8"</td> <td>EM – 1"</td> <td>MH – 14mm</td> <td>MN – 20mm</td> <td>MT – 26mm</td> </tr> <tr> <td>EH – 11/16"</td> <td>EN – 1 1/16"</td> <td>MI – 15mm</td> <td>MO – 21mm</td> <td>MU – 27mm</td> </tr> <tr> <td>EI – 3/4"</td> <td>EO – 1 1/8"</td> <td>MJ – 16mm</td> <td>MP – 22mm</td> <td>XX – Special</td> </tr> <tr> <td>EJ – 13/16"</td> <td>EP – 1 3/16"</td> <td>MK – 17mm</td> <td>MQ – 23mm</td> <td></td> </tr> </table>						EE – 1/2"	EK – 7/8"	EQ – 1 1/4"	ML – 18mm	MR – 24mm	EF – 9/16"	EL – 15/16"	MG – 13mm	MM – 19mm	MS – 25mm	EG – 5/8"	EM – 1"	MH – 14mm	MN – 20mm	MT – 26mm	EH – 11/16"	EN – 1 1/16"	MI – 15mm	MO – 21mm	MU – 27mm	EI – 3/4"	EO – 1 1/8"	MJ – 16mm	MP – 22mm	XX – Special	EJ – 13/16"	EP – 1 3/16"	MK – 17mm	MQ – 23mm							
EE – 1/2"	EK – 7/8"	EQ – 1 1/4"	ML – 18mm	MR – 24mm																																					
EF – 9/16"	EL – 15/16"	MG – 13mm	MM – 19mm	MS – 25mm																																					
EG – 5/8"	EM – 1"	MH – 14mm	MN – 20mm	MT – 26mm																																					
EH – 11/16"	EN – 1 1/16"	MI – 15mm	MO – 21mm	MU – 27mm																																					
EI – 3/4"	EO – 1 1/8"	MJ – 16mm	MP – 22mm	XX – Special																																					
EJ – 13/16"	EP – 1 3/16"	MK – 17mm	MQ – 23mm																																						

Note: When ordering, specify the base tool and order the socket separately. The socket will be installed in the tool before shipment.

Tube Nut Wrenches

Clecomatic Clutch

Cleco®

24 Series

Torque Range:
14 - 40 Nm
19 - 54 Ft. Lbs

- One hand, two position throttle
- External torque adjustment
- Auto alignment socket



24 Series (T2)

24 Series (T3)

24 Series (T4)

24 Series Power Unit
With Auto Alignment

Termination

T2, T3 & T4 Head Height

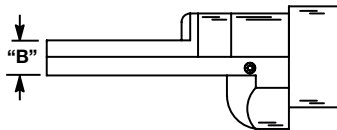

T2 Head

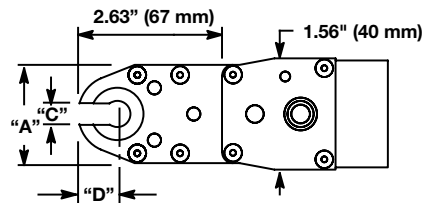

T3 Head

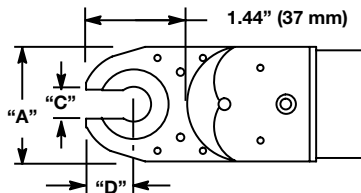

T4 Head

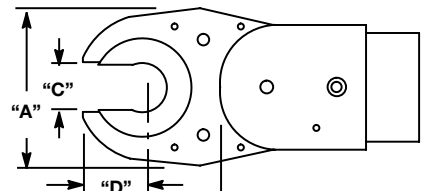

NOTE: Models listed are examples. Use chart on bottom of facing page for specific model required but not listed.

Model Number	Free Speed RPM	Torque Range		Weight		Length		Socket Size		"A"		"B"		"C"*		"D"	
		Ft. Lbs.	Nm	lbs.	kg	in.	mm	in.	mm	in.	mm	in.	mm	in.	mm	in.	mm
Power Unit Only																	
24RTA12	670	3.6 - 8.9	5 - 12	2.7	1.2	12	305	NA	NA	NA	NA	NA	NA	NA	NA	NA	NA
Self Aligning																	
24RTA20T2	240	10.4 - 14.7	14 - 20	4.3	2.0	16.8	426	7/16	—	1.42	36	0.55	14	0.28	7.0	0.53	13.5
24RTA30T3	175	14.7 - 22.1	20 - 30	4.5	2.0	16.7	426	9/16	—	1.65	42	0.59	15	0.47	11.9	0.73	18.5
24RTA40T4	130	19.2 - 29.5	26 - 40	5.1	2.3	17.7	449	7/8	—	2.36	60	0.59	15	0.67	17.0	0.93	23.5

* Varies by socket dimension.

General:

Air Inlet: 1/4" NPT

Tool performance rated at 90 psi (620kPa) air pressure.

Extra Equipment:

Specify socket from page 45

Optional Equipment:

Torque signal kit: 201900 (see page 49)



Auto Alignment Head

Tube and hose applications, once only accessible by the use of hand tools, can now be tightened by the Cleco family of Tube Nut Wrenches at a speed that maximizes productivity.

Torque repeatability is assured by the proven Clecomatic clutch and low inertia motor. These models use a single lever for the tightening of the fastener and the return of the socket to the open position. The flexibility coupled with the proven capabilities greatly increases the productivity rate of the assembly line.



Make sure that the socket is set to the open position. If not, push the throttle lever down half way to release the socket back to the open position.



Slide the tool on the fastener and push the throttle lever down fully to run the fastener down.



To free the tool, slide the tool off the tightened fastener and operate the throttle lever halfway to release the socket back to the open position.

Model Number Example

Base Tool					Socket (Order Separately)				
24	R	T	A	20	T2	KS2	ED	0	0
Motor 24	Tool Style R – Reversing mechanism for socket orientation		Tool Type T – Tube Nut	Torque Control A – Clecomatic Clutch		Head Type KS2 - T2 KS3 - T3 KS4 - T4		Output Type 0 Partial Thru Hex 2 Double Thru Hex 1 Thru Hex 6 Partial Thru Double Hex	
Max Torque (Nm) T2 - 20 Nm T3 - 30 Nm T4 - 40 Nm				Extension Length 0 Flush 4 1/2" 2 1/4" 6 3/4"		Maximum Hex Socket Sizes MG, 1/2" T2 Head Type MM, 3/4" T3 Head Type MU, 1 1/16" T4 Head Type 00, ## (specials) T3 Head Type			
Head Size T2 - 20 Nm Max. T3 - 30 Nm Max. T4 - 40 Nm Max.				Socket Sizes					
				EA – 1/4"		M5 – 5mm		MK – 17mm	
				EC – 3/8"		M6 – 6mm		ML – 18mm	
				ED – 7/16"		MA – 7mm		MM – 19mm	
				EE – 1/2"		MB – 8mm		MN – 20mm	
				EF – 9/16"		MD – 10mm		MO – 21mm	
				EH – 11/16"		ME – 11mm		MP – 22mm	
				EJ – 13/16"		MF – 12mm		MQ – 23mm	
				EK – 7/8"		MG – 13mm		MR – 24mm	
				EM – 1"		MH – 14mm		MS – 25mm	
				EO – 1 1/8"		MI – 15mm		MT – 26mm	
				EP – 1 3/16"		MJ – 16mm (5/8")		MU – 27mm (1 1/16")	
				EQ – 1 1/4"					

Note: When ordering, specify the base tool and order the socket separately. The socket will be installed in the tool before shipment.

Nutrunner Accessories

Torque Reaction Bars & Slave Square Drives

Part No.	Description	Used On
869770	Steel Bar	45, 55 series inline
48047128	Steel Bar	64...D4 series
46037081	Slave Square Drive	64...D4 series
46177030	Slave Square Drive	64...D6 series
46607058	Slave Square Drive	64...D8 series

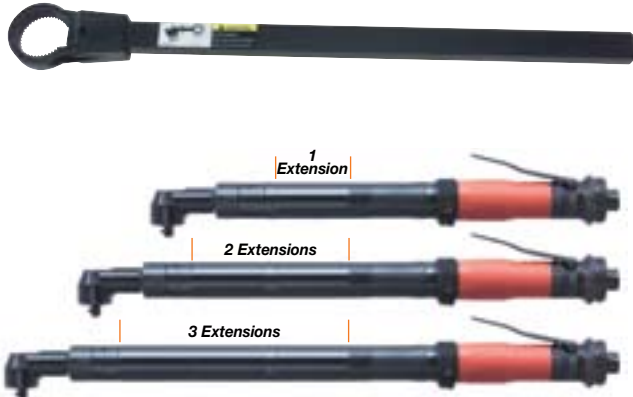

Extension Kit (3.5")

Part No.	Used On
301081	34 series (37 Nm or higher)
301108	24/34 series (36 Nm or lower)

Mounting Brackets (right angle tools)

Part No.	Description	Used On
201012	Torque reaction bracket	45, 55 series
201039	Fixed tooling bracket	45, 55 series
201510	Torque reaction bracket	75 series
201034	Torque reaction bracket	75 series (standard)

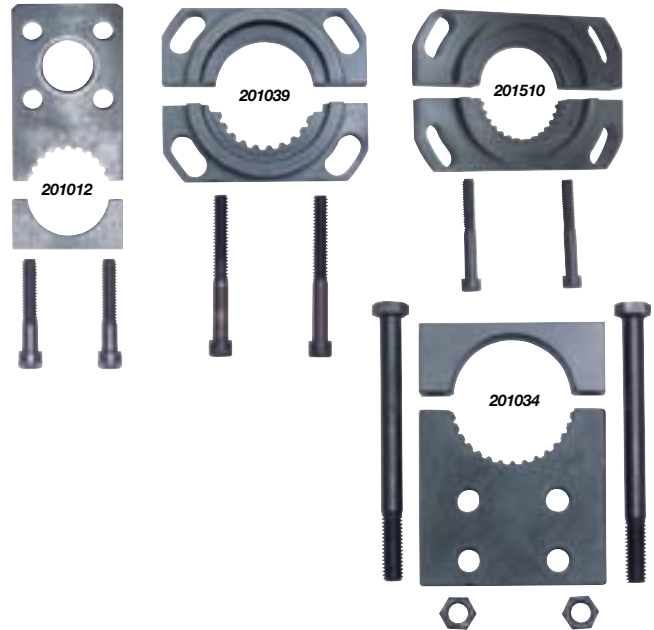

Anglehead Covers

Part No.	Used On	
	Tool Series	Anglehead
205831	24/34	AH, AM
205833	24/34	AX
205834	24/34	AZ
205837	14	AH
205839	45/55	T
205835	45/55	P
205838	75	V



Joint Simulator

Description	Torque Range		Width		Height		Length		Part No.
	ft.-lbs.	Nm	in.	mm	in.	mm	in.	mm	
Joint Simulator	220-12	300-15	10.4	264	16	406	26	667	550006

Suspension Bail

Part No.	Used On
867711	8, 35, 45, 55 series



Swivel Suspension Bail

Part No.	Used On
541715-5	24, 34 series
54397004	64...D4 series
46437006	64...D6 series
46607016	64...D8 series
46037036	64...D12 series

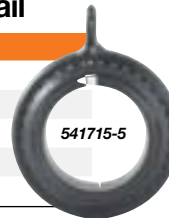

Torque Signal Kit

Air signal to indicate clutch shut-off.

Part No.	Used On
201900	24/34 Clecomatic
301106	14 Clecomatic



Assembly Wrench

Part No.	Used On
201898	Two required



Cleco®

The TVP-100 Series Torque Verifier provides low-cost assembly assurance for pneumatic screwdrivers, nutrunners and pulse tools.

The Cleco TVP-100 verifier improves your assembly process by eliminating operator error caused by early trigger release, fastener cross-threading or re-hits.

The TVP-100 is designed for use with pneumatic clutch screwdrivers/nutrunners and Cleco shut-off pulse tools equipped with torque signal kits.

The TVP-100 provides visual and audio feedback

for both individual fastener and batch parameters, assuring that every fastener has been rundown to the capability of the tool.

Based on existing Cleco TME controller technology, the TVP-100 navigational screen allows for simple set-up and operation.

The TVP-100 works by reading the signature of a ported pneumatic assembly tool through its fastening cycle. Any deviation from the normal signature caused by re-hits, cross threads, early trigger release or a number of variables will elicit a **NOK** visual and audio signal from the verifier, notifying the operator of an error. Whereas a Cleco DC controller controls the tool and the fastening process, the TVP-100 is a cost-effective way of verifying torque by following the torque signature of a tool.



Accessories

Cleco TVP-100 Series Torque Verifier

Features

- Verifies fastener installation with **OK/NOK** audio and visual indicators
- On screen verification of individual fastener assembly status with batch count
- VGA screen displays graph for each rundown
- Stores 1,000 rundowns
- Sequencing capability
- 8 parameter sets available for multiple applications
- “Auto Cal” permits fast and easy tool set up for any joint type
- Password protected
- Multiple languages



TVP-100 Series Torque Verifiers

Model Number		Language	Weight		Width		Height		Depth	
115VAC*	230VAC*		lbs.	kg	in.	mm	in.	mm	in.	mm
TVP-110-15-U	TVP-110-30-U	English	6	2.72	8.75	222	9.13	232	4.13	105
TVP-110-15-D	TVP-110-30-D	German	6	2.72	8.75	222	9.13	232	4.13	105
TVP-110-15-S	TVP-110-30-S	Spanish	6	2.72	8.75	222	9.13	232	4.13	105
TVP-110-15-P	TVP-110-30-P	Portuguese	6	2.72	8.75	222	9.13	232	4.13	105

** 230V units are CE compliant.

All model numbers include power cable, air signal transducer, 25 foot cable to connect TVP to air signal transducer, and 8 foot air line to connect transducer to tool.
NOTE: Tool must be equipped with torque signal kit.

24 Volt Inputs/Outputs:

Inputs: Up to 8 Applications
 Reset
 Suspend

Outputs: Cycle Accept
 Batch Accept
 Reject

Accessories

Torque Signal Kits

Part No.	Tool Used On
301106	14SCA and 14RAA series
301118	14TTA series
301119	14PTA series
201900	24RAA and 34RAA series
934918	PTH series pulse tools (“C” & “D” vintage only)

Phoenix Connector

Part No.	Description
542892	24 Volt Input/Output Phoenix connector
939348	Strain relief for above connector

Cables

Part No.	Description
207237	115V Transducer and cable
207238	230V Transducer and cable

**115V and 230V transducer and cable assemblies have different connectors at the TVP end of the cable.*



Cleco Ratchet Wrenches. For Applications That Are “Impossible” To Get To.

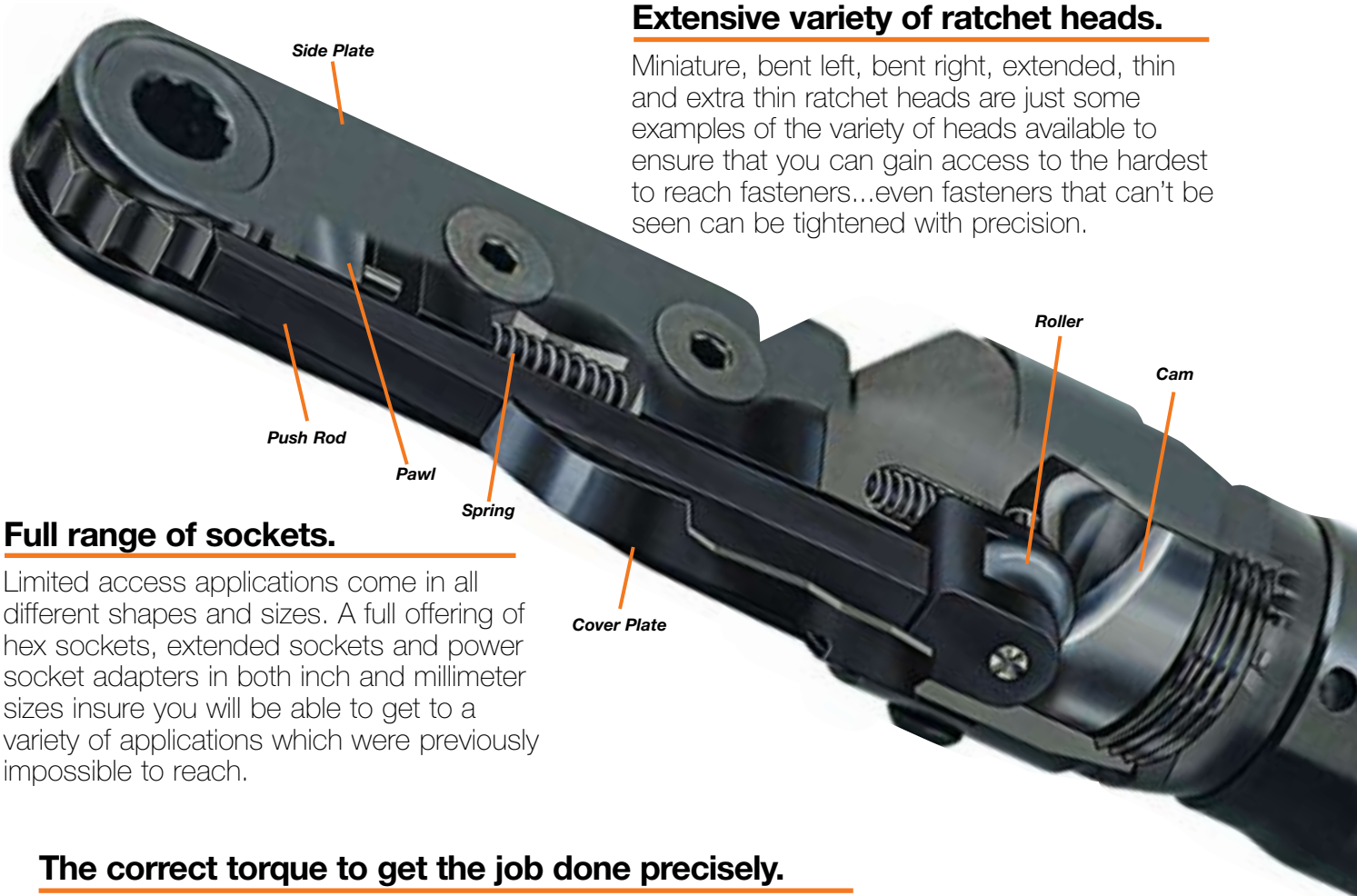

Extensive variety of ratchet heads.

Miniature, bent left, bent right, extended, thin and extra thin ratchet heads are just some examples of the variety of heads available to ensure that you can gain access to the hardest to reach fasteners...even fasteners that can't be seen can be tightened with precision.

Full range of sockets.

Limited access applications come in all different shapes and sizes. A full offering of hex sockets, extended sockets and power socket adapters in both inch and millimeter sizes insure you will be able to get to a variety of applications which were previously impossible to reach.

The correct torque to get the job done precisely.

Cleco 24 and 34 series ratchet wrenches are available in sizes up to 50 Ft.Lbs. Several sizes of side plate widths and thicknesses are available to provide a wide range of torques without sacrificing size or durability.

Success in simplicity.

By using a single direction stall motor the Cleco 24 and 34 series ratchet wrenches eliminate components that traditionally add cost and decrease service life. With this tool you truly get what you pay for. A very economical and dependable solution for the hardest to reach fasteners. Need a reversible tool? No problem, simply flip the tool over.

Gears that have stood up to the test of time.

The key wear items in the ratchet head (gears, cams, and push rods) have remained unchanged from the previous H16 and H30 tools. Not only can you have confidence in their durability, you won't have to buy new replacement parts.



Improved motor for better performance.

Innovative low inertia motor design provides more usable power in a smaller package size. The end result is a more ergonomic handle for a more productive tool. The same successful motor is used on Cleco flush socket, crowfoot, hold-and-drive and standard Clecomatic clutch shut-off nutrunners.

Ergonomic grip for operator comfort.

Rubber coated motor housing helps isolate the operator from temperature changes.



Easy assembly/disassembly with a standard spanner wrench.

Hardened steel bearing plates resist wear and assures longer life.

Cleco[®]

Ratchet Wrenches

Stall Type

Cleco®

24 & 34 Series

Torque Range:
up to 68.3 Nm
up to 50.4 Ft. Lbs

- Stall type
- Non-Reversible



Cleco 24/34 Series Model Number Nomenclature

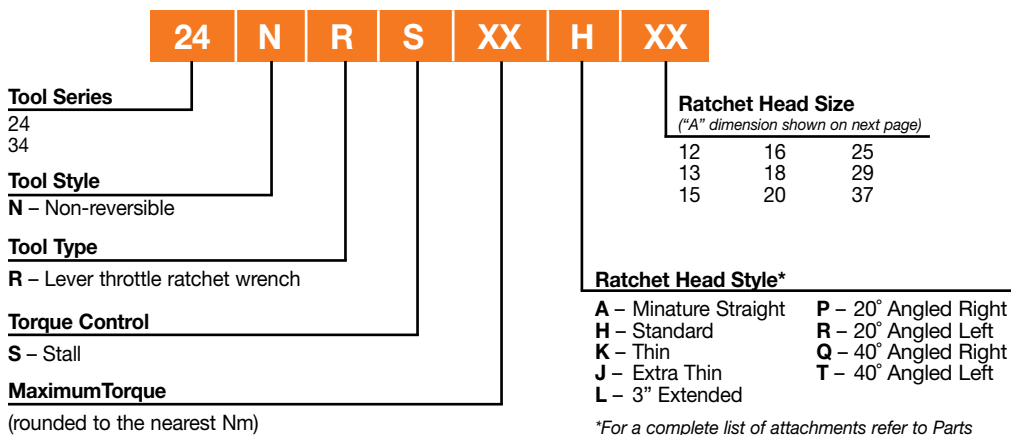

*For a complete list of attachments refer to Parts Manual #PL17-RA

Ratchet Wrenches

Stall Type

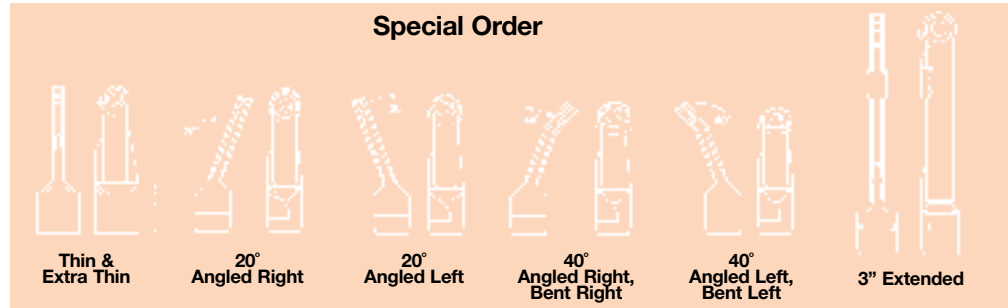
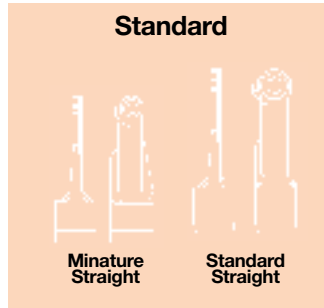

Other head types are available. Contact your Cooper Power Tools sales representative.

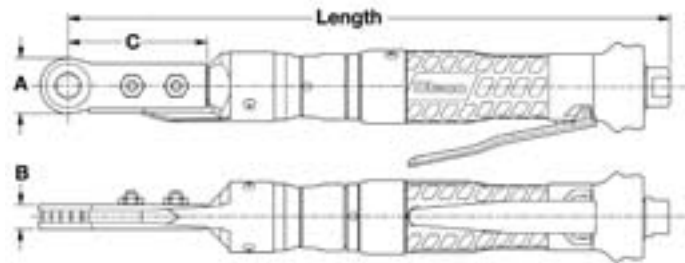

Model Number	Free Speed	Maximum Torque		Maximum Socket Size		"A"		"B"		"C"		Length		Weight		
	RPM	Ft. Lbs.	Nm	in.	mm	in.	mm	in.	mm	in.	mm	in.	mm	lbs.	kg	
24 Series																
24NRS15A13	265	11.0	14.9	7/16	11	13/16	20.6	1/2	12.7	2.88	73.2	13.4	340	2.7	1.2	
24NRS15A12	285	11.1	15.0	3/8	10	3/4	19.0	1/2	12.7	2.88	73.2	13.4	340	2.7	1.2	
24NRS20H15	305	14.8	20.1	1/2	13	15/16	23.8	9/16	14.2	3.13	79.5	14.0	356	2.9	1.3	
24NRS21H16	285	15.4	20.9	9/16	16	1	25.4	9/16	14.2	3.13	79.5	14.0	356	3.0	1.3	
24NRS23A13	145	17.2	23.3	7/16	11	13/16	20.6	1/2	12.7	2.88	73.2	14.2	361	2.9	1.3	
24NRS23H15	170	17.3	23.5	1/2	13	15/16	23.8	9/16	14.2	3.13	79.5	14.8	376	3.1	1.4	
24NRS23H20	250	17.5	23.7	3/4	19	1 1/4	31.8	9/16	14.2	3.13	79.5	14.2	361	3.0	1.4	
24NRS24H16	155	17.7	24.0	9/16	16	1	25.4	9/16	14.2	3.13	79.5	14.8	376	3.2	1.4	
24NRS24H18	265	18.0	24.4	5/8	16	1 1/8	28.6	9/16	14.2	3.13	79.5	14.1	358	3.0	1.4	
24NRS24A12	155	18.3	24.8	3/8	10	3/4	19.0	1/2	12.7	2.88	73.2	14.2	361	2.9	1.3	
24NRS29H18	145	21.4	29.0	5/8	16	1 1/8	28.6	9/16	14.2	3.13	79.5	14.9	378	3.2	1.5	
24NRS29H25	180	21.5	29.1	15/16	24	1 9/16	39.7	9/16	14.2	3.25	82.5	14.4	366	3.1	1.4	
24NRS30H20	135	22.0	29.8	3/4	19	1 1/4	31.8	9/16	14.2	3.13	79.5	14.9	378	3.2	1.5	
24NRS33H29	165	24.6	33.4	1 1/8	29	1 13/16	46.0	5/8	15.9	3.50	88.9	14.9	378	3.3	1.5	
24NRS34H25	100	25.6	34.7	15/16	24	1 9/16	39.7	9/16	14.2	3.25	82.5	15.2	386	3.3	1.5	
24NRS39H37	140	28.9	39.2	1 5/8	41	2 11/32	59.5	5/8	15.9	3.75	95.3	15.3	389	3.6	1.7	
24NRS43H29	90	32.2	43.7	1 1/8	29	1 13/16	46.0	5/8	15.9	3.50	88.9	15.7	399	3.5	1.6	
24NRS52H37	80	38.8	52.6	1 5/8	41	2 11/32	59.5	5/8	15.9	3.75	95.3	16.1	409	3.8	1.7	
34 Series																
34NRS29H15	255	21.6	29.3	1/2	13	15/16	23.8	9/16	14.2	3.13	79.5	16.0	406	3.7	1.7	
34NRS31H16	240	22.9	31.0	9/16	16	1	25.4	9/16	14.2	3.13	79.5	16.0	406	3.7	1.7	
34NRS35H20	210	25.9	35.1	3/4	19	1 1/4	31.8	9/16	14.2	3.13	79.5	16.2	411	3.7	1.7	
34NRS36H18	225	26.7	36.2	5/8	16	1 1/8	28.6	9/16	14.2	3.13	79.5	16.1	409	3.7	1.7	
34NRS36H15	155	26.8	36.3	1/2	13	15/16	23.8	9/16	14.2	3.13	79.5	16.8	427	3.9	1.8	
34NRS38H16	145	28.1	38.1	9/16	16	1	25.4	9/16	14.2	3.13	79.5	16.8	427	3.9	1.8	
34NRS42H25	150	30.9	41.9	15/16	24	1 9/16	39.7	9/16	14.2	3.25	82.5	16.4	417	3.8	1.7	
34NRS46H20	125	33.9	46.0	3/4	19	1 1/4	31.8	9/16	14.2	3.13	79.5	17.0	432	4.0	1.8	
34NRS46H18	135	34.1	46.2	5/8	16	1 1/8	28.6	9/16	14.2	3.13	79.5	16.9	429	4.0	1.8	
34NRS48H29	140	35.1	47.6	1 1/8	29	1 13/16	46.0	5/8	15.9	3.50	88.9	16.9	429	4.0	1.8	
34NRS52H25	90	38.4	52.1	15/16	24	1 9/16	39.7	9/16	14.2	3.25	82.5	17.2	437	4.1	1.8	
34NRS53H37	120	38.9	52.7	1 5/8	41	2 11/32	59.5	5/8	15.9	3.75	95.3	17.3	439	4.4	2.0	
34NRS63H29	85	46.7	63.3	1 1/8	29	1 13/16	46.0	5/8	15.9	3.50	88.9	17.7	450	4.2	1.9	
34NRS68H37	70	50.4	68.3	1 5/8	41	2 11/32	59.5	5/8	15.9	3.75	95.3	18.1	460	4.6	2.1	

General:
Air Inlet: 1/4" NPT
Tool performance rated at 90 psi (620kPa) air pressure.

Standard Equipment:
Suspension bail, hex socket

Socket Selection:
See pages 55-57

Ratchet Wrenches

Clutch Type

GARDNER-DENVER®

H16, H30, 41 & 60 Series

Torque Range:
up to 415 Nm
up to 306 Ft. Lbs

- Clutch activated air shut-off (H16, H30 & 60 series)
Air shut-off (41 series)
- Non-Reversible



Model Number	Free Speed	Maximum Torque		Maximum Socket Size		"A"		"B"		"C"		Weight		Length	
	RPM	Ft. Lbs.	Nm	in.	mm	in.	mm	in.	mm	in.	mm	lbs.	kg	in.	mm
H16NDR09H15	130	10.0	13.5	1/2	13	15/16	23.8	9/16	14.2	3.13	79.5	4.3	2.0	18.9	480
H30NDR08H15	120	12.0	16.2	1/2	13	15/16	23.8	9/16	14.2	3.13	79.5	4.9	2.2	20.6	523
41NDR236H15	360	23.0	31.1	1/2	13	15/16	23.8	9/16	14.2	3.13	79.5	5.7	2.6	17.7	449
41NDR172H15	265	32.0	43.3	1/2	13	15/16	23.8	9/16	14.2	3.13	79.5	5.7	2.6	17.7	449
41NDR130H15	200	42.0	56.9	1/2	13	15/16	23.8	9/16	14.2	3.13	79.5	6.1	2.8	18.8	478
H30NDR08H16	110	13.0	17.6	5/8	16	1	25.4	9/16	14.2	3.13	79.5	4.9	2.2	20.6	523
41NDR236H16	335	25.0	33.8	5/8	16	1	25.4	9/16	14.2	3.13	79.5	5.7	2.6	17.7	449
41NDR172H16	245	34.0	46.0	5/8	16	1	25.4	9/16	14.2	3.13	79.5	5.7	2.6	17.7	449
41NDR130H16	185	45.0	60.9	5/8	16	1	25.4	9/16	14.2	3.13	79.5	6.1	2.8	18.8	478
H30NDR08H18	105	18.0	24.3	5/8	16	1 1/8	28.6	9/16	14.2	3.13	79.5	4.9	2.2	20.7	526
41NDR236H18	315	29.0	39.2	5/8	16	1 1/8	28.6	9/16	14.2	3.13	79.5	5.8	2.6	17.7	449
41NDR130H18	170	52.0*	70.4	5/8	16	1 1/8	28.6	9/16	14.2	3.13	79.5	6.1	2.8	18.8	478
H16NDR09H20	110	16.0	21.6	3/4	19	1 1/4	31.8	9/16	14.2	3.13	79.5	4.4	2.0	19.1	485
H30NDR08H20	100	19.0	25.7	3/4	19	1 1/4	31.8	9/16	14.2	3.13	79.5	4.9	2.2	20.8	528
41NDR172H20	215	42.0	56.9	3/4	19	1 1/4	31.8	9/16	14.2	3.13	79.5	5.8	2.6	17.7	449
41NDR130H20	160	56.0*	75.8	3/4	19	1 1/4	31.8	9/16	14.2	3.13	79.5	6.1	2.8	18.8	478
60NDR092HD24	95	122.0	165.3	3/4	19	1 1/2	38.1	7/8	22.4	6.19	157.2	16.9	7.7	27.4	697
H30NDR08H25	70	22.0	29.8	15/16	24	1 9/16	39.7	9/16	14.2	3.25	82.5	5.0	2.3	21.0	533
41NDR172H25	155	53.0*	71.8	15/16	24	1 9/16	39.7	9/16	14.2	3.25	82.5	5.8	2.6	17.8	452
41NDR130H25	115	70.0*	94.8	15/16	24	1 9/16	39.7	9/16	14.2	3.25	82.5	6.1	2.8	18.9	481
60NDR092HD40	60	212.0	287.2	1 1/2	38	2 1/2	63.5	7/8	22.4	6.69	169.9	17.2	7.8	28.4	722
60NDR092HD48	50	252.0	341.4	1 15/16	49	3	76.2	1	25.4	6.94	176.3	17.7	8.0	28.9	735
60NDR092HD56	40	306.0	415.0	2-3/8	60	3 1/2	88.9	1	25.4	7.25	184.2	18.0	8.2	29.5	749

General:

Air Inlet: 1/4" NPT (H16, H30),
3/8" NPT (41), 1/2" NPT (60)
Tool performance rated at 90 psi (620kPa) air pressure.

Standard Equipment:

H16, H30: Suspension bail, hex socket
41: Hex socket
60: Hex socket, reaction bar collar
(1/2" hex opening for reaction bar)

Socket Selection:

See pages 54-56

*WARNING: these terminations are not recommended for applications over 50 Ft. Lbs. (68 Nm) torque.

Ratchet Wrenches

Hex Socket Selection Charts



Standard Length 24, 34, H16, H30, 41 Series *(No additional cost)*

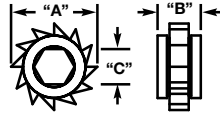

Termination		12	13	15	16	18	20	25	29	37
"A"		3/4	13/16	15/16	1	1 1/8	1 1/4	1 9/16	1 13/16	2 11/32
"B"		1/2	1/2	9/16	9/16	9/16	9/16	9/16	5/8	5/8
"C"		Socket Part Numbers								
Hex*										
1/4"	S.H.	28000	28020	28048	28075					
1/4"	D.H.	28001	28021	28051						
9/32"	S.H.	28012								
5/16"	S.H.	28002	28022	28040	28056		28101	28135		
5/16"	D.H.	28003	28023	28052	28078		28124			30434
11/32"	S.H.	28004	28024		28074	28097	28102			
11/32"	D.H.	28005								
3/8"	S.H.	28006	28026	28041	28057	28094	28160			
3/8"	D.H.	28007	28027	28042	28058		28123	28166		
7/16"	S.H.	28009†	28029	28043	28060	28081	28105	28136	28192	30418
7/16"	D.H.	28010†	28030	28044	28061	28082	28106	28137		30435
1/2"	S.H.		28031†	28046	28063	28083	28108	28139	28170	30423
1/2"	D.H.		28032†	28047	28064	28084	28109	28140		
9/16"	S.H.				28066	28087	28111	28141	28171	30432
9/16"	D.H.				28067	28088	28112	28142	28189	
5/8"	S.H.				28069†	28090	28115	28144	28172	
5/8"	D.H.				28070†	28091	28116	28145	28190	30431
11/16"	S.H.						28118	28146	28173	30433
11/16"	D.H.						28119	28147		
3/4"	S.H.						28121	28148	28174	30429
3/4"	D.H.						28122	28149	28191	
13/16"	S.H.							28150	28175	
13/16"	D.H.							28151		
7/8"	S.H.							28154		30427
7/8"	D.H.							28155		
15/16"	S.H.							28156	28179	30430
15/16"	D.H.								28180	30434
1"	S.H.								28181	30428
1"	D.H.								28182	
1-1/16"	S.H.								28183	30436
1-1/16"	D.H.								28184	
1-1/8"	S.H.								28185	30417
1-1/8"	D.H.								28187	
1-3/16"	S.H.									30425
1-1/4"	S.H.									30419
1-5/16"	S.H.									30426
1-7/16"	S.H.									30420
1-1/2"	S.H.									30421
1-1/2"	D.H.									30437
1-5/8"	S.H.									30422
6 mm	S.H.	28016	28033	28055						
7 mm	S.H.	28017	28034	530440			28126	28163		
8 mm	S.H.	28002	28022	28040	28056					
8 mm	D.H.	28003	28023		28078					
9 mm	S.H.				28071					
9 mm	D.H.		28037							
10 mm	S.H.	28008	28028	28054	28059	28093	28104	28164		
11 mm	S.H.	28009†	28029	28043	28060	28081		28136	530460	
12 mm	S.H.			28045	28062		28107	28138		
13 mm	S.H.		28036	28053	28077	28096	28125	28161	530461	
14 mm	S.H.			530441	28065	28086	28110	28159		
15 mm	S.H.				28068	28089	28113	28143	530462	532431
15 mm	D.H.				28080	28095				
16 mm	S.H.					28099		28167		
17 mm	S.H.					28092	28117	28158	28193	
18 mm	S.H.						28120	28165		30439
19 mm	S.H.						28121	28148	28174	30429
19 mm	D.H.						28122	28149	28191	
21 mm	S.H.							28152		
22 mm	S.H.							28162		
23 mm	S.H.								28178	
24 mm	S.H.							28168		
29 mm	S.H.								28188	

* S.H. = Single Hex; D.H. = Double Hex

† FRAGILE: For light duty operations only.

Ratchet Wrenches

Hex Socket Selection Charts

Standard Length

60 Series (No additional cost)

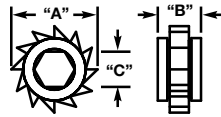

Termination	24	32	40	48	56	
"A"	1 1/2	2	2 1/2	3	3 1/2	
"B"	7/8	7/8	7/8	1	1	
"C"	Hex*	Socket Part Numbers				
1/2"	S.H.	29015	29053		29121	
1/2"	D.H.	29016				
9/16"	S.H.	29017				
9/16"	D.H.	29018				
5/8"	S.H.	29019	29035			
5/8"	D.H.	29020	29036			
11/16"	S.H.	29021	29037	507159		
11/16"	D.H.		29038			
3/4"	S.H.	29023	29039	507157	29115	
3/4"	D.H.	29024	29040		523737	
13/16"	S.H.		29041	29055		
13/16"	D.H.		29042			
7/8"	S.H.		29043	29057	29150	
7/8"	D.H.		29044	29058		
15/16"	S.H.		29045	29059	29111	
15/16"	D.H.		29046	29060	29112	
1"	S.H.		29047	29061	29116	
1"	D.H.		29048	29062	29147	
1 1/16"	S.H.		29049	29063	29114	
1 1/16"	D.H.		29050	29064	29146	
1 1/8"	S.H.		29051†	29065	29090	
1 1/8"	D.H.		29052†	29066	29091	
1 3/16"	S.H.			29075	29118	
1 1/4"	S.H.			29067	29092	
1 1/4"	D.H.			29068	29093	
1 5/16"	S.H.			29069	29094	
1 5/16"	D.H.			29070	29095	
1 3/8"	S.H.				29117	
1 7/16"	S.H.			29071	29096	
1 7/16"	D.H.			29072	29123	
1 1/2"	S.H.			29073	29098	
1 1/2"	D.H.			29074	29125	
1 9/16"	S.H.				29152	
1 5/8"	S.H.				29100	
1 5/8"	D.H.				29101	
1 11/16"	S.H.				29128	
1 11/16"	D.H.				29129	
1 3/4"	S.H.				29103	
1 13/16"	S.H.				29108	
1 13/16"	D.H.				29104	
1 13/16"	D.H.				29131	
1 7/8"	S.H.				29132	
1 15/16"	S.H.				29133	
2"	S.H.				29110†	
2 1/16"	S.H.				29135	
2 1/16"	D.H.				29137	
2 3/16"	S.H.				29138	
2 1/4"	S.H.				29139	
2 3/8"	S.H.				29141	
2 3/8"	S.H.				29143†	
15 mm	S.H.	29028	507135		507161	
18 mm	S.H.	29027				
21 mm	S.H.	29029	507136			
22 mm	S.H.		507134			
24 mm	S.H.		507132	507160	29119	
26 mm	S.H.		507133	507157		
29 mm	S.H.		507134			
36 mm	S.H.			29079	523738	

Power Socket Adapters

Adapts grooved sockets to square drive. Use with conventional square drive socket. (additional cost)

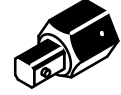

Part Number	Hex Size	Square Drive	Overall Length
A-312	3/8"	3/8"	0.94"
A-314	7/16"	3/8"	0.94"
A-514	7/16"	1/2"	1.09"
A-516	1/2"	1/2"	1.16"
A-518	9/16"	1/2"	1.16"
A-520	5/8"	1/2"	1.13"
A-524	3/4"	1/2"	1.13"

Extended Length 24, 34, H16, H30, 41 Series

(Additional cost. Provides CCW tightening.)

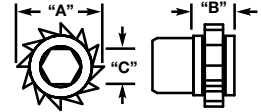

Termination	12	13	15	16	18	20	25	29
"A"	3/4	13/16	15/16	1	1 1/8	1 1/4	1 9/16	1 13/16
"B"	1/2	1/2	9/16	9/16	9/16	9/16	9/16	5/8
"C"	Hex*	Ext.	Socket Part Numbers					
5/16"	S.H.	1/2"						
3/8"	S.H.	1/4"	20966					
3/8"	D.H.	1/4"				28652		
7/16"	S.H.	1/4"				28650		
7/16"	S.H.	1/2"				501056		
1/2"	S.H.	1/4"				28645		
1/2"	S.H.	1/2"				501059		
1/2"	S.H.	5/8"					501061	
1/2"	S.H.	3/4"				501054		
9/16"	S.H.	3/8"				501051		
9/16"	S.H.	1/2"				501053		
9/16"	S.H.	7/8"				28649		
5/8"	S.H.	3/8"				28648†		
1 3/16"	S.H.	3/4"					501062	
13 mm	S.H.	1/2"					501063	

Double Extended 24, 34, H16, H30, 41 Series

(Additional cost)

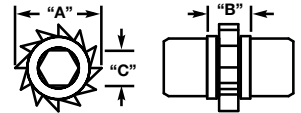

Termination	12	13	15	16	18	20	29
"A"	3/4	13/16	15/16	1	1 1/8	1 1/4	1 13/16
"B"	1/2	1/2	9/16	9/16	9/16	9/16	5/8
"C"	Hex*	Ext.	Socket Part Numbers				
5/16"	S.H.	1/4"	10642				
5/16"	D.H.	1/2"				501222	
3/8"	S.H.	3/8"				501225	
7/16"	S.H.	1/4"	18950				
7/16"	S.H.	1/2"				28787	
1/2"	D.H.	1/8"				28654	
1/2"	S.H.	1/4"				28663	28789
1/2"	S.H.	7/16"				501221	
1/2"	D.H.	1/2"				28660	
9/16"	S.H.	1/8"				28659	
9/16"	D.H.	1/8"				28655	
9/16"	S.H.	1/4"				28656	
9/16"	D.H.	3/8"				28657	
9/16"	S.H.	1/2"					28791
9/16"	D.H.	1/2"					501231
11/16"	S.H.	1/2"					28793
3/4"	D.H.	3/8"					28797†
3/4"	S.H.	3/4"					28661
13 mm	S.H.	1/4"				501229	530024
13 mm	S.H.	3/8"				501226	
13 mm	S.H.	1/2"				530741	530028
13 mm	S.H.	3/4"				530742	531201
15 mm	S.H.	1/4"				501227	530025
15 mm	S.H.	3/8"				501228	530001
15 mm	S.H.	1/2"					501233
15 mm	S.H.	1/2"					530026
15 mm	S.H.	3/4"					530003
15 mm	S.H.	3/4"					531200
							530004

* S.H. = Single Hex; D.H. = Double Hex

† FRAGILE: For light duty operations only.

Extended Length H16, H30, 41 Series

(Additional cost. Provides CW tightening.)

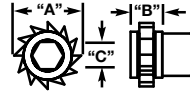

Termination	12	13	15	16	18	20	25	29
"A"	3/4	13/16	15/16	1	1 1/8	1 1/4	1 9/16	1 13/16
"B"	1/2	1/2	9/16	9/16	9/16	9/16	9/16	5/8
"C"	Hex*	Ext.	Socket Part Numbers					
1/4"	S.H. 1/4"	28300						
1/4"	D.H. 3/8"		508406					
1.4"	D.H. 1/2"	28314						
5/16"	S.H. 1/4"	28301	28331		28353			
5/16"	D.H. 1/4"	28316		28387				
5/16"	S.H. 3/8"	28302	28333	28338				
5/16"	D.H. 3/8"		28335	28352				
5/16"	S.H. 1/2"	28320		28350	516546			
5/16"	S.H. 3/4"				28392			
5/16"	S.H. 7/8"	28313						
11/32"	S.H. 1/4"	28303						
11/32"	S.H. 1/2"		28336					
11/32"	S.H. 3/4"	29304						
3/8"	D.H. 1/8"			28347	28384			
3/8"	S.H. 1/4"	28305	29323	28339	28354			
3/8"	D.H. 1/4"	28317			28386			
3/8"	S.H. 3/8"	28306	28324		28385	28407		
3/8"	S.H. 1/2"	28307			28355	28441		
3/8"	D.H. 1/2"	28308						
3/8"	S.H. 5/8"	28319						
3/8"	D.H. 5/8"		28325					
3/8"	S.H. 3/4"	28309			28356	28408		
3/8"	D.H. 3/4"				28389			
3/8"	S.H. 7/8"		28326					
3/8"	S.H. 1"			28340				
3/8"	D.H. 1"			28351				
7/16"	S.H. 1/8"			508399				
7/16"	S.H. 1/4"	28310†	28327	28341	28357		28439	
7/16"	D.H. 1/4"		28334	28342	28358			
7/16"	S.H. 3/8"	28311†	28328		28359	28409		
7/16"	S.H. 1/2"	28312	28329	28343	28360	28405	28410	
7/16"	S.H. 5/8"			28344				
7/16"	D.H. 5/8"			508397				
7/16"	S.H. 3/4"				28361	28411		
7/16"	S.H. 7/8"				28362			
7/16"	D.H. 1"			508398				
1/2"	S.H. 1/8"			508400	28363			
1/2"	D.H. 1/8"			508404				
1/2"	S.H. 1/4"			28345	28364	28406	28412	
1/2"	D.H. 1/4"			28348	28365			
1/2"	S.H. 3/8"		28330		28366	28413	28465	28469
1/2"	S.H. 1/2"				28367	28402	28414	28478
1/2"	D.H. 1/2"			28349	28368			
1/2"	S.H. 5/8"				28369	28401		28466
1/2"	D.H. 5/8"			28346		28437		
1/2"	S.H. 3/4"				28370	28404	28415	
1/2"	S.H. 7/8"					28416		
1/2"	S.H. 1"				28371			
9/16"	S.H. 1/8"				28372			
9/16"	S.H. 1/4"				28373	28395	28418	28471
9/16"	D.H. 1/4"				28374			
9/16"	S.H. 3/8"				28375†	28396		
9/16"	D.H. 3/8"				28376†	28440		
9/16"	S.H. 1/2"				28377†	28403	28419	28463
9/16"	D.H. 1/2"				28378†	28420	517065	
9/16"	S.H. 5/8"				28379†	28397		
9/16"	S.H. 3/4"				28393†	28421	28468	
9/16"	D.H. 3/4"					28444	28464	
9/16"	S.H. 7/8"				28280†			
9/16"	D.H. 7/8"				516547			
9/16"	S.H. 1"						517061	
5/8"	S.H. 1/8"						28422	
5/8"	S.H. 1/4"				28381†		28452	28479
5/8"	D.H. 1/4"					28423		
5/8"	S.H. 3/8"				28382†			
5/8"	S.H. 1/2"				28388†	28399	28424	28453
5/8"	S.H. 5/8"						28454	
5/8"	S.H. 3/4"					28400	28426	28455

* S.H. = Single Hex; D.H. = Double Hex

† FRAGILE: For light duty operations only.

Termination	12	13	15	16	18	20	25	29
"A"	3/4	13/16	15/16	1	1 1/8	1 1/4	1 9/16	1 13/16
"B"	1/2	1/2	9/16	9/16	9/16	9/16	9/16	5/8
"C"	Hex*	Ext.	Socket Part Numbers					
5/8"	D.H. 1"							28428
11/16"	S.H. 1/4"							28438
11/16"	D.H. 1/4"							28430
11/16"	S.H. 3/8"							28431 28456
11/16"	S.H. 1/2"							28432 514830
11/16"	S.H. 1"							517062
3/4"	S.H. 1/4"							28433†
3/4"	S.H. 3/8"							28458
3/4"	S.H. 1/2"							28434
3/4"	S.H. 3/4"							28435 28459 28476
3/4"	S.H. 1"							28436 28470
7/8"	S.H. 1/4"							517063
7/8"	D.H. 5/8"							28461
7/8"	S.H. 1"							28462
15/16"	S.H. 1/2"							28474
1"	S.H. 1/2"							28472
1-1/8"	S.H. 1/2"							28477
6 MM	S.H. 1/4"	530453						
6 MM	S.H. 1/2"	28321						
7 MM	S.H. 1/4"	530454			516554			
7 MM	S.H. 1/2"	28322			516553			
8 MM	S.H. 1/4"	530455			516558			
8 MM	S.H. 1/2"	530450			516555			
10 MM	S.H. 1/4"	530456			516559			
10 MM	S.H. 3/8"	533472			28390			
10 MM	S.H. 1/2"	530451	508405	516556				
11 MM	S.H. 1/4"	530457			530515			
11 MM	S.H. 1/2"	530452			516557			
12 MM	S.H. 1.2"				530520			
13 MM	S.H. 1/8"				28391			
13 MM	S.H. 1/4"		533470		28394			
13 MM	S.H. 3/8"					525137		
13 MM	S.H. 1/2"		533471		516552			
13 MM	S.H. 1"				530519			
14 MM	S.H. 1/4"				530516		28449	
14 MM	S.H. 1/2"						28417 517070	
15 MM	S.H. 1/4"				530517		28450 517067	
15 MM	D.H. 1/4"				530518			
15 MM	S.H. 3/8"						28451	
15 MM	D.H. 3/8"				28630			
15 MM	S.H. 1/2"				516551		28447 517066	
15 MM	D.H. 1/2"				516550			
15 MM	S.H. 3/4"						28446	
17 MM	S.H. 1/4"						28448	
17 MM	S.H. 3/8"							517068 514831
17 MM	S.H. 1/2"						28429 517060 514829	
17 MM	D.H. 1"						28445	
18 MM	S.H. 3/4"						543176 17069	

Grooved 24, 34, H16, H30, 41 Series

Use with Power Socket Adapters (Additional cost)

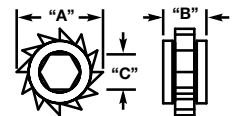

Termination	12	13	15	16	20	25	29
"A"	3/4	13/16	15/16	1	1 1/4	1 9/16	1 13/16
"B"	1/2	1/2	9/16	9/16	9/16	9/16	5/8
"C"	Socket Part Numbers						
1/4"	28741						
5/16"	28740						
3/8"	28739						
7/16"	28742	504772	28745	28750	28751		25737
1/2"			28746	28748	28752		28766
9/16"					28753		28768
5/8"					28754		
3/4"					28755		28767



Cleco Pulse Tools = Productivity

The Cleco D Series pulse tool family combines our legendary durability with our customer's increasing demands for productivity.

Industry first motor design and revolutionary preventative maintenance distance the new D Series from the competition. With outstanding ergonomics, you'll never want to put this tool down.

D Series redefines productivity by performing the job faster and staying on the job longer.

Designed to assemble products where quality, high production and efficiency are paramount, these tools prove their value over and over. Consistent performance, unmatched durability and ease of use and maintenance make these tools the tools of choice.

■ Broad Tool Selection

With a variety of shut-off and nonshut-off pulse tools to choose from you're sure to find just the right Cleco pulse tool for the job.



3X Increase Between Oil Changes

- Adjustable pulse chamber volume
- Tool achieves full torque after preventative maintenance
- No special tools required

The average tool is out of service almost 20 minutes for maintenance of hydraulic impulse unit.

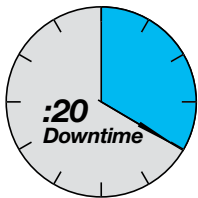

Average Tool

With Cleco's patented design, maintenance time is only 2 minutes!

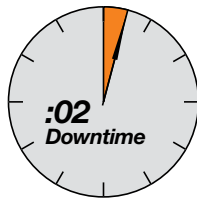

New Cleco D Series



The new D Series, shown actual size, is considerably smaller and lighter than the old 55PTH ghosted in the background.

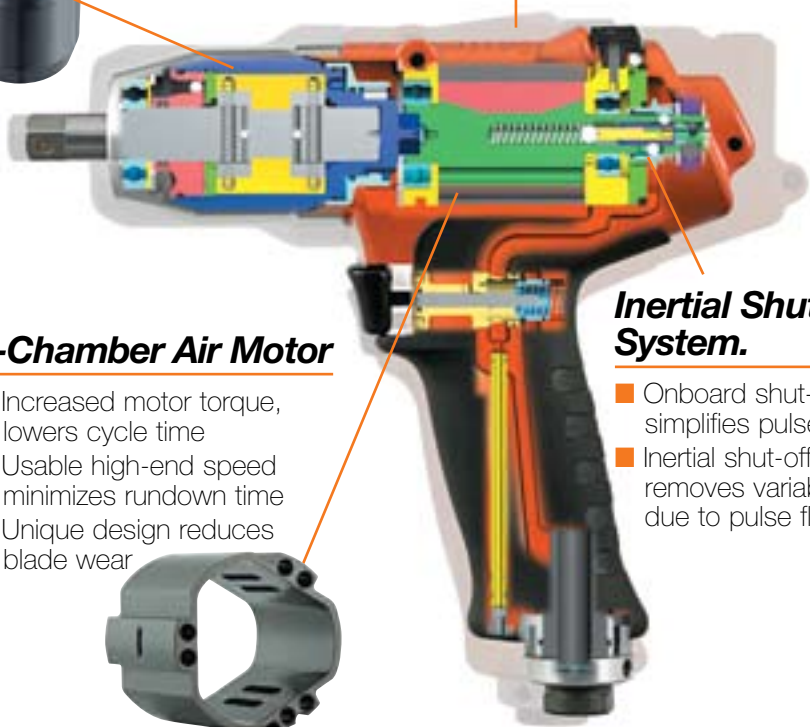

3-Chamber Air Motor

- Increased motor torque, lowers cycle time
- Usable high-end speed minimizes rundown time
- Unique design reduces blade wear

Inertial Shut-off System.

- Onboard shut-off simplifies pulse unit
- Inertial shut-off removes variability due to pulse fluid

Low Vibration Levels

Double chamber hydraulic units and 3-chamber motors mean extremely low vibration levels are achieved. This aids in preventing Cumulative Trauma Disorders (CTDs).

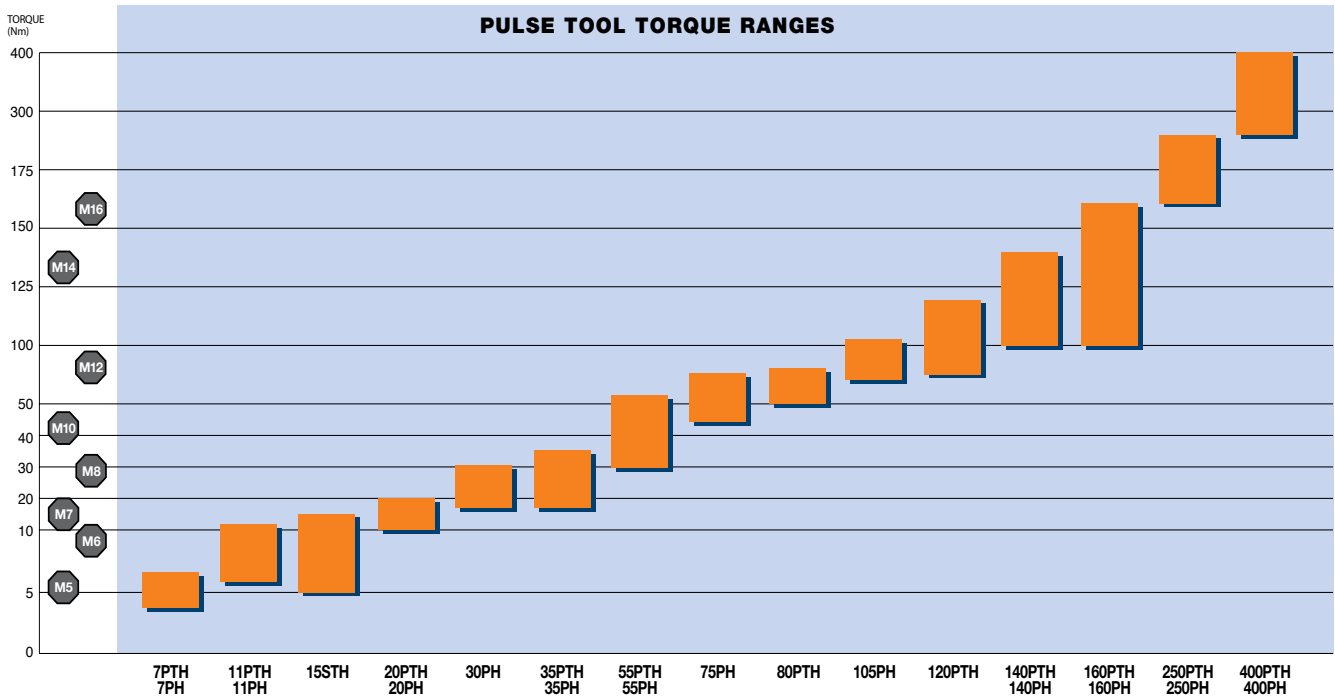

Low Noise Levels

Noise levels of these tools are well below standard air tools for an operator-friendly environment. There is no loud metallic hammering under load.



Ships Ready For Error Proofing

- Works with existing TVP torque verifier
- Located near air inlet to maximize ergonomics



Standard air signal indicating tool shutoff for use with Cleco TVP Error Proofing System.

Easy Set-Up

- Insert 2mm hex into rear port of tool
- Positive stops in both directions to prevent loss and/or damage



Adjustable Motor Speed

- Easily adjustable motor speed to insure accuracy on hard joints
- Can be locked in place to prevent accidental adjustment



Pulse Nutrunners

Hydraulic Pulse Shut-Off & Non Shut-Off



D-Series

Torque Range:
6 - 120 Nm
4.4 - 88.5 Ft. Lbs

Bolt Size:
M5 - M12
#10 - 1/2"

- Inertia shut-off
- External torque adjustment
- External speed control
- Reversible
- Torque signal port
- Adjustable pulse unit volume simplifies maintenance
- Oilless blades 



C-Series PTH & STH

Torque Range:
100 - 400 Nm
74 - 295 Ft. Lbs

Bolt Size:
M12 - M20
1/2" - 3/4"

- Hydraulic pulse shut-off
- Motor governor equipped
- External torque adjustment
- External speed control
- Reversible
- Oilless blades 
- Torque signal port



C-Series PH Non-Shut-Off

Torque Range:
4 - 400 Nm
3 - 295 Ft. Lbs

Bolt Size:
M5 - M18
#10 - 3/4"

- External speed control
- Reversible
- Oilless blades 

Model Number Nomenclature

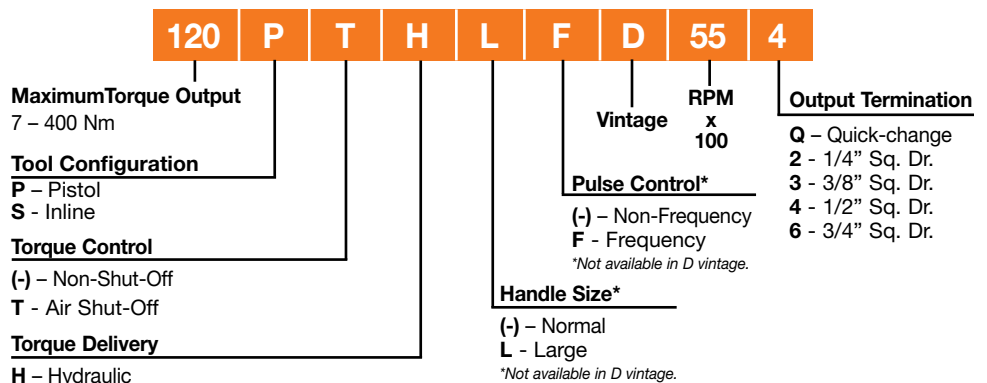

Model Number	Drive Type*	Torque Range		Free Speed	Weight*		Air Consumption		
		Ft.Lbs.	Nm		RPM	lbs.	kg	NPT	Hose I.D.
D-Series – Pistol Grip – Shut-off Models									
11PTH65Q	1/4" QC	4.4-8.1	6-11	6500	1.87	0.85	1/4"	3/8"	12.3
11PTH652	1/4" Sq.Dr.	4.4-8.1	6-11	6500	1.87	0.85	1/4"	3/8"	12.3
11PTH653	3/8" Sq.Dr.	4.4-8.1	6-11	6500	1.87	0.85	1/4"	3/8"	12.3
20PTH75Q	1/4" QC	7.3-14.7	10-20	7500	1.92	0.87	1/4"	3/8"	12.3
20PTH753	3/8" Sq.Dr.	7.3-14.7	10-20	7500	1.90	0.86	1/4"	3/8"	12.3
35PTH65Q	1/4" QC	14.7-25.8	20-35	6500	2.2	1.0	1/4"	3/8"	16.0
35PTH653	3/8" Sq.Dr.	14.7-25.8	20-35	6500	2.2	1.0	1/4"	3/8"	16.0
55PTH603	3/8" Sq.Dr.	22.1-40.5	30-55	6000	2.4	1.1	1/4"	3/8"	19.0
80PTH60Q	7/16" QC	36.9-59.0	50-80	6000	3.2	1.45	1/4"	3/8"	19.0
80PTH604	1/2" Sq.Dr.	36.9-59.0	50-80	6000	3.1	1.4	1/4"	3/8"	19.0
110PTH55Q	7/16" QC	55.3-81.1	75-110	5500	3.75	1.7	3/8"	1/2"	30.0
120PTH554	1/2" Sq.Dr.	55.3-81.1	75-120	5500	3.75	1.7	3/8"	1/2"	30.0
C-Series – Pistol Grip – Shut-off Models									
140PTH25Q	7/16" QC	74-103	100-140	2500	5.7	2.6	3/8"	1/2"	25.4
160PTH256	3/4" Sq.Dr.	74-118	100-160	2500	5.7	2.6	3/8"	1/2"	25.4
C-Series – Pistol Grip – Shut-off Models – Trigger Throttle									
250PTHFC226	3/4" Sq.Dr.	118-184	160-250	2200	8.8	4.0	3/8"	1/2"	33.5
400PTHFC206	3/4" Sq.Dr.	185-295	250-400	2000	11.7	5.3	3/8"	1/2"	33.5
C-Series – In-Line – Push-to-Start									
7STHFA55Q	1/4" QC	1.9-4.9	2.6-6.6	5500	1.8	0.83	1/8"		7.0
35STHFA40Q	7/16" QC	12-26	15-35	4000	3.1	1.4	1/4"	3/8"	15.9
35STHFA404	1/2" Sq.Dr.	12-26	15-35	4000	2.9	1.3	1/4"	3/8"	15.9
C-Series – In-Line – Lever									
7STHFC55Q	1/4" QC	1.9-4.9	2.6-6.6	5500	2.1	0.93	1/8"		7.0
15STHFC40Q	1/4" QC	3.6-11	5.0-15	4000	2.4	1.1	1/4"	3/8"	16.5
35STHFC40Q	7/16" QC	12-26	15-35	4000	3.3	1.5	1/4"	3/8"	15.9
35STHFC404	1/2" Sq.Dr.	12-26	15-35	4000	3.3	1.5	1/4"	3/8"	15.9
15STH40Q	1/4" QC	3.6-11	5.0-15	3000	2.4	1.1	1/4"	3/8"	16.5

(*) Approximate values. Some variance may occur between square and Q drives.

General:
Tool performance rated @ 87 psi (6 bar) air pressure.

Standard Equipment:
Suspension bail and torque adjusting wrench.
Torque signal port (pistol grip models only)

Optional Equipment:
Additional accessories: Page 62

Model Number	Drive Type*	Torque Range		Free Speed	Weight*		Air Consumption		
		Ft.Lbs.	Nm		RPM	lbs.	kg	NPT	Hose I.D.
C-Series – Pistol Grip – Non-Shut-off Models									
7PHL90Q	1/4" QC	3.0-5.2	4-7	9000	1.8	0.8	1/4"	3/8"	8.8
11PHL80Q	1/4" QC	4.4-8.1	6-11	8000	1.9	0.9	1/4"	3/8"	8.8
11PHL802	1/4" Sq.Dr.	4.4-8.1	6-11	8000	1.9	0.9	1/4"	3/8"	8.8
20PHL70Q	1/4" QC	7.4-14	10-20	7000	2.3	1.1	1/4"	3/8"	15.9
20PHL703	3/8" Sq.Dr.	7.4-14	10-20	7000	2.3	1.1	1/4"	3/8"	15.9
30PHL70Q	1/4" QC	13-22	17-30	7000	2.6	1.2	1/4"	3/8"	15.9
35PHL703	3/8" Sq.Dr.	13-26	17-35	6500	2.6	1.2	1/4"	3/8"	15.9
55PHL60Q	7/16" QC	22-40	30-55	6000	3.7	1.7	1/4"	3/8"	21.2
55PHL604	1/2" Sq.Dr.	22-40	30-55	6000	3.7	1.7	1/4"	3/8"	21.2
75PHL50Q	7/16" QC	33-55	45-75	5000	4.0	1.8	1/4"	3/8"	19.4
75PHL504	1/2" Sq.Dr.	33-55	45-75	5000	4.0	1.8	1/4"	3/8"	19.4
105PH55Q	7/16" QC	52-77	70-105	5500	5.3	2.4	3/8"	1/2"	24.7
105PH554	1/2" Sq.Dr.	52-77	70-105	5500	5.3	2.4	3/8"	1/2"	24.7
140PH45Q	7/16" QC	74-103	100-140	4500	5.7	2.6	3/8"	1/2"	31.7
160PH456	3/4" Sq.Dr.	74-118	100-160	4500	5.7	2.6	3/8"	1/2"	31.7
250PHF406	3/4" Sq.Dr.	118-184	160-250	4000	8.6	3.9	3/8"	1/2"	40.6
400PHF356	3/4" Sq.Dr.	184-295	250-400	3500	11.5	5.2	3/8"	1/2"	42.3

(*) Approximate values. Some variance may occur between square and Q drives. For 7-75 Series Models, small handle can be ordered by substituting "S" for "L" in model number.

General:
Tool performance rated @ 87 psi (6 bar) air pressure.

Standard Equipment:
Suspension bail and torque adjusting wrench.

Optional Equipment:
Additional accessories: Page 62

Pulse Tool Accessories

D Series Maintenance Items

Pulse Tool	Pulse Unit	Air Motor	Pulse Repair Kit	Motor Repair Kit	Filler Connector
7PTHD602	935953	935955	935717	935716	931968
7PTHD60Q	935952	935955	935717	935716	931968
11PTHD75Q	935700	935687	935717	935716	931968
11PTHD752	935700	935687	935717	935716	931968
11PTHD753	935700	935687	935717	935716	931968
20PTHD75Q	935700	935687	935717	935716	931968
20PTHD753	935700	935687	935717	935716	931968
35PTHD65Q	935485	935408	935495	935494	931968
35PTHD653	935484	935408	935495	935494	931968
55PTHD603	935483	935408	935493	935492	931968
80PTHD60Q	935640	935635	935656	935655	935718
80PTHD604	935641	935635	935656	935655	935718
110PTHD55Q	935642	935657	935654	935653	935718
120PTHD554	935643	935657	935654	935653	935718

Rubber Tool Stand



Part Number	Tool Series
931041 (one piece)	C Series 7PTH - 105PTH/PH D Series 7PTH - 120PTH
930119 (two pieces)	C Series 140/160PTH/PH/ 250PTH / 400PTH

Hydraulic Oil

Part Number	Container Size
539317	One Quart



Torque Signal Kit

Air signal to indicate shut-off.

Part Number	Tool Series
934918	PTH series pulse tools (C & D vintage shut-off tools only)

7/16" Quick Change Chuck Adapter

Part Number	Tool Series
935472	To convert 55PTHD603 to a Quick-Change chuck



Hydraulic Filler Unit

Part Number			C Series Tools
Filler Unit Only	Connector Only	Filler Unit Complete	
928483	931968	542523	7/11PTH/PH/SH 20/35PTH/PH/SH
928483	932072	928477	55/75PTH/PH 105/140/160PTH/PH



Lined area for notes.



Cleco®

Telescopic Impact Wrenches

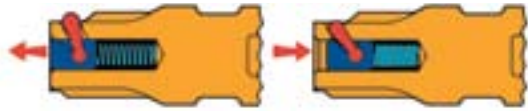

Patented Positive Lock Socket Retainer

With the patented positive lock socket retainer (U.S. Pat 3, 890,051), sockets snap on...and stay on until released. Offered on spline drives, the retainer can be serviced without disassembling the tool.

Exclusive through-bolt construction reduces replacement costs

Steel front end/motor housing/handle are clamped together by four high-strength steel bolts. This exclusive feature provides better tool performance, eliminates stripped threads and loose inserts in motor housing.



Positive oil-foam lubrication system reduces major cause of impact wrench maintenance.

Cleco impact wrenches feature a unique oil-foam bath that provides positive lubrication for the hammer, anvil and other working parts.



The system is designed so that if the impact mechanism runs low on 30 wt. oil, the tool will stop running, thus eliminating one of the major causes of impact wrench failure ... lack of lubrication. By simply refilling the oil reservoir, the tool can be returned to service. Other impact wrenches soon throw off grease; run dry causing extra wear that shortens tool life and increases maintenance cost.

Proven heavy-duty patented telescoping impact mechanism adds power...cuts weight...reduces shock to the operator.

The smooth-hitting Cleco telescopic impact mechanism is patented (U.S. Pat. 3,156,3340) and has only three major parts - hammer, anvil and rotor... providing more power directly to the fastener. The hammer is splined to the inside of the motor, which then impacts directly on the anvil, delivering more power per blow.

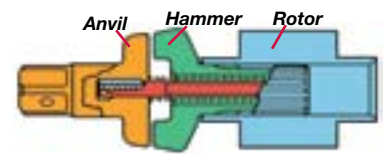

Other important features include:

- Comfortable grip handle
- Outside, inside triggers and pistol grip models
- Multiposition dead handle, and spade type "D" handle available
- Throttle can be feathered for speed control
- Simple face-type reversing valve simplifies maintenance
- Forged hammer and anvil for greater durability
- Rotor bearings and steel motor end plates fit either end of motor, reducing spare parts inventory and repair time.

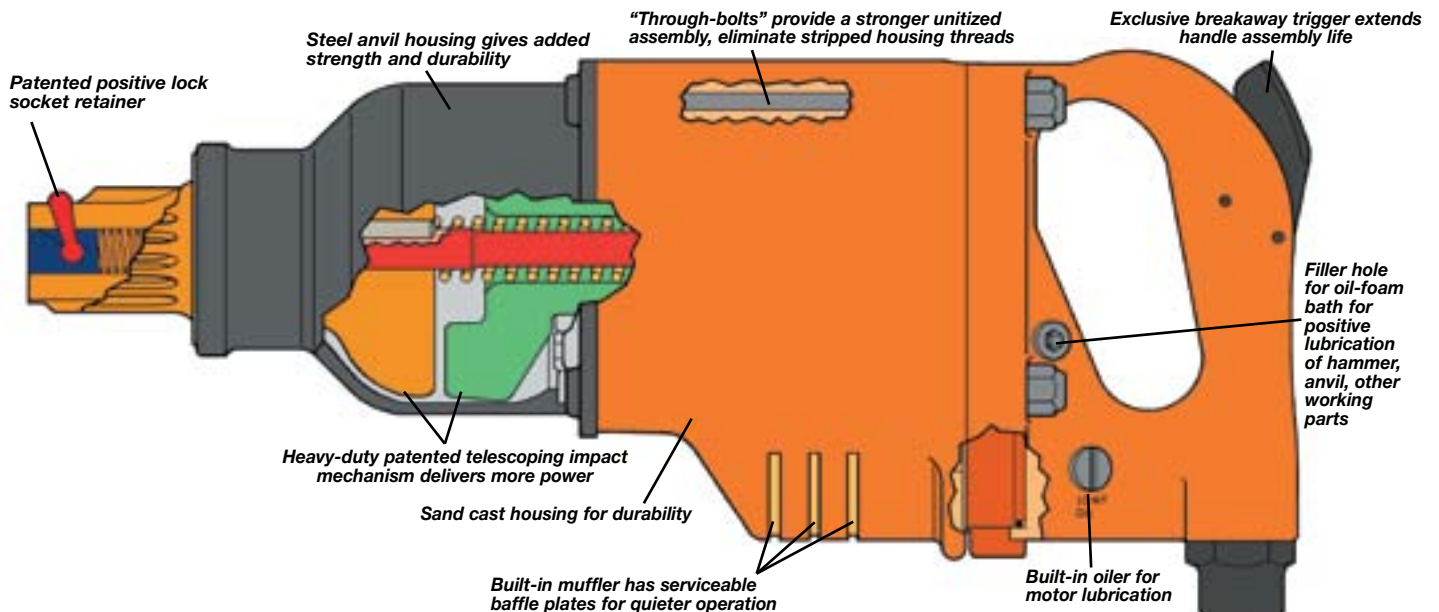

Bolt Selection Chart

The Impact Wrench Bolt Selection Chart will assist you in selecting impact wrenches for specific applications. Torque and tension figures are based on 70% of the proof load of a given size and grade UNC bolt. Torque values are based on non-lubricated (dry) conditions. Bolt grades and sizes are those which are the most commonly secured with impact wrenches.

SAE Grade 1

Bolt Diameter		1/4"	5/16"	3/8"	7/16"	1/2"	9/16"	5/8"	3/4"	7/8"	1"	1-1/8"	1-1/4"	1-3/8"	1-1/2"	1-5/8"	1-3/4"
Torque	Ft.-lb.	3	6	11	18	28	43	55	97	155	230	340	480	660	860	-	-
	Nm	4.1	8.1	15	24	38	58	75	132	210	312	460	650	900	1,170	-	-
Tension	lb.	730	1,210	1,800	2,460	3,280	4,200	5,200	7,000	10,000	14,000	18,200	23,000	28,000	34,600	-	-
	kN	3.24	5.38	8.0	10.9	14.6	18.7	23.1	31.1	47.1	62.3	81	102	126	154	-	-

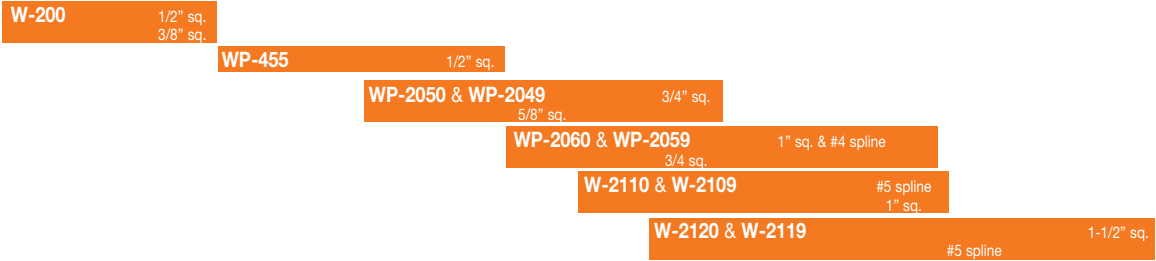

SAE Grade 5

Bolt Diameter		1/4"	5/16"	3/8"	7/16"	1/2"	9/16"	5/8"	3/4"	7/8"	1"	1-1/8"	1-1/4"	1-3/8"	1-1/2"	1-5/8"	1-3/4"
Torque	Ft.-lb.	8	16	28	46	70	110	140	250	405	600	770	1,080	1,470	1,950	-	-
	Nm	10.8	21.7	38	62	95	149	190	340	550	810	1,040	1,460	1,930	2,640	-	-
Tension	lb.	1,900	3,100	4,600	6,350	8,450	10,900	13,500	20,000	27,400	36,000	41,000	52,000	64,000	77,000	-	-
	kN	8.4	13.8	20.4	28.2	37.6	48.5	60	89	122	160	182	231	285	342	-	-

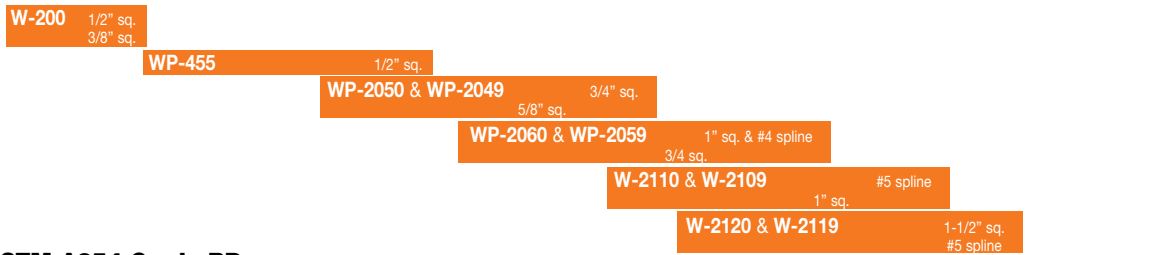

SAE Grade 8 / ASTM-A354 Grade BD

Bolt Diameter		1/4"	5/16"	3/8"	7/16"	1/2"	9/16"	5/8"	3/4"	7/8"	1"	1-1/8"	1-1/4"	1-3/8"	1-1/2"	1-5/8"	1-3/4"
Torque	Ft.-lb.	11	23	40	65	99	159	198	350	566	848	1,245	1,750	2,375	3,135	-	-
	Nm	14.9	31.2	54.2	88	134	216	268	475	767	1,150	1,690	2,370	3,220	4,250	-	-
Tension	lb.	2,740	4,400	6,510	8,930	11,920	15,290	18,980	28,050	38,800	50,900	66,360	84,000	103,570	125,330	-	-
	kN	12.2	19.6	28.9	39.7	53	68	84.4	125	172	226	295	374	461	557	-	-

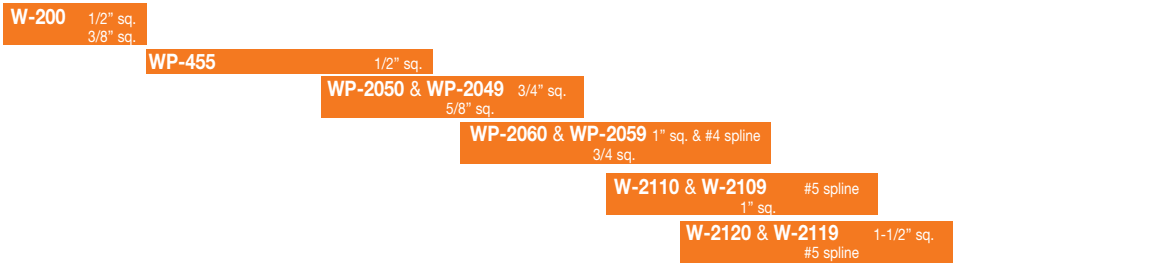

ASTM A325*

Bolt Diameter		1/4"	5/16"	3/8"	7/16"	1/2"	9/16"	5/8"	3/4"	7/8"	1"	1-1/8"	1-1/4"	1-3/8"	1-1/2"	1-5/8"	1-3/4"
Torque	Ft.-lb.	1						200	355	570	850	1,060	1,495	1,960	2,600	-	-
	Nm							271	481	773	1,150	1,440	2,030	2,660	3,530	-	-
Tension	lb.							10,000	28,000	39,000	51,000	56,000	71,000	85,000	103,000	-	-
	kN							44.5	124	173	227	249	316	378	458	-	-



ASTM A490*

Bolt Diameter		1/4"	5/16"	3/8"	7/16"	1/2"	9/16"	5/8"	3/4"	7/8"	1"	1-1/8"	1-1/4"	1-3/8"	1-1/2"	1-5/8"	1-3/4"
Torque	Ft.-lb.	1						250	435	715	1,070	1,580	2,125	2,780	3,700	-	-
	Nm							339	590	970	1,451	2,125	2,882	3,770	5,020	-	-
Tension	lb.							24,000	35,000	49,000	64,000	80,000	102,000	121,000	148,000	-	-
	kN							107	156	218	285	356	454	538	658	-	-



*Note: ASTM-325 and ASTM A490 bolts are used on structural steel applications. Torque and tension values are based on running the nut beyond the proof load of the bolt by the turn-of-the-nut method. For detailed information, consult the bolt manufacturer.

Impact Wrenches

Inline, Pistol Grip & Spade Handle

Cleco®

WL & WP Series

Torque Range:	Bolt Size:
20 - 2450 Nm	M10 - M30
15 - 1800 Ft. Lbs	7/16" - 1 1/2"

- Lever and trigger start
- Reverse or forward bias
- 6" extended and spline drives available



WT Series Spade Handle

Torque Range:	Bolt Size:
1000 - 4000 Nm	M30 - M36
750 - 3000 Ft. Lbs	1 3/8" - 1 1/2"

- Inside or outside lever
- Positive lock socket retainer (spline drive)
- Multiposition dead handle
- Oil foam bath
- Reverse or forward bias



Model Number	Bolt Size		Square Drive	Recommended Torque Range		Impacts per Minute	Free Speed	Length		Weight		Side to Center		Air Consumption			
	Gr. 5	Gr. 9.8		ft.-lbs.	Nm			RPM	in.	mm	lbs.	kg	in.	mm	NPT	Hose I.D.	SCFM
	in.	mm															
Inline – Lever Start																	
WL-200-BQ	7/16	M10	7/16*	15-50	20-68	3,200	3,000	8.5	216	3.1	1.4	1	25	1/4"	1/4"	18	
WL-200-3	7/16	M10	3/8	15-50	20-68	3,200	3,000	8.5	216	3.1	1.4	1	25	1/4"	1/4"	18	
WL-200-4	1/2	M10	1/2	15-60	20-81	3,200	3,000	8.5	216	3.4	1.5	1	25	1/4"	1/4"	18	
Pistol Grip – Trigger Start																	
WP-255-3P	7/16	M10	3/8	60-75	80-100	1,150	9,500	5.7	145	2.6	1.2	1	25	1/4"	1/4"	30	
WP-455-4R	1/2	M20	1/2	37-370	50-502	1,400	6,500	7	176	5.3	2.4	-	-	1/4"	1/4"	30	
WP-455-4P***	1/2	M20	1/2	37-370	50-502	1,400	6,500	7	176	5.3	2.4	-	-	1/4"	1/4"	30	
WP-2050-6	7/8	M20	3/4	125-600	170-800	1,000	6,000	6.4	162	7.8	3.5	1.6	42	3/8"	3/8"	45	
WP-2060B-6	1 1/8	M24	3/4	250-700	350-950	1,000	4,000	7.8	197	12	5.4	1.8	46	3/8"	3/8"	60	
WP-2060B-8	1 1/8	M24	1	250-900	350-1200	1,000	4,000	7.8	197	12.1	5.5	1.8	46	3/8"	3/8"	60	
WP-2110B-8	1 3/8	M30	1	750-1650	1000-2250	880	4,600	9.5	241	20.8	9.4	2.2	56	1/2"	3/8"	100	
Pistol Grip – Trigger Start – Biased Reverse Power****																	
WP-2049-6	7/8	M20	3/4	125-550	170-750	1,000	6,200	6.4	162	7.8	3.5	1.6	42	3/8"	3/8"	45	
WP-2059-6	1 1/8	M24	3/4	250-700	350-950	1,000	4,000	7.8	197	12	5.4	1.8	46	3/8"	3/8"	60	
WP-2059-8	1 1/8	M24	1	250-800	350-1100	1,000	4,000	7.8	197	12.1	5.5	1.8	46	3/8"	3/8"	60	
WP-2059-8-6E**	1 1/8	M24	1	250-750	350-1000	1,000	4,000	13.8	350	14.3	6.5	1.8	46	3/8"	3/8"	60	
WP-2109B-8	1 3/8	M30	1	750-1650	1000-2250	880	4,300	9.5	241	20.8	9.4	2.2	56	1/2"	3/8"	100	
WPS-2109B	1 3/8	M30	#5 Spl.	750-1800	1100-2450	880	4,300	9.8	248	21.3	9.6	2.2	56	1/2"	3/8"	100	

* Quick change chuck
 ** 6" Extended spindle
 *** Pin retainer
 ****Breakaway torque capacity in reverse:
 2049 Series: 750 ft.-lbs. (1000 Nm)
 2059 Series: 1200 ft.-lbs. (1600 Nm)
 2109 Series: 2500 ft.-lbs. (3400 Nm)

General:
 Tool performance rated at 90 psi (620kPa) air pressure.
Standard Equipment:
 Operating instructions & service manual

Optional Equipment:
 86909 Suspension bail for WL-200.
 Additional accessories: Pages 68-73

Model Number		Suitable for Bolt Size		Square Drive	Recommended Torque Range		Impacts Per Minute	Free Speed	Length		Weight		Side to Center		Air Consumption			
Inside Trigger	Outside Trigger	in.	mm		ft.-lbs.	Nm			RPM	in.	mm	lbs.	kg	in.	mm	NPT	Hose I.D.	SCFM
Trigger Start - Spade Handle																		
	WT-2110-8		1 1/2	M30	1	750-1650	1000-2250	880	4,600	12.9	327	21	9.5	2.2	56	1/2"	1/2"	100
	WTS-2120		1 1/2	M36	#5 Spl.	1200-2800	1600-3800	850	3,300	14.3	362	27.6	12.5	2.3	59	1/2"	5/8"	105
	WT-2120-12	W-2120-12	1 1/2	M36	1 1/2	1200-3000	1600-4000	850	3,300	14.3	362	27.6	12.5	2.3	59	1/2"	5/8"	105
Trigger Start - Spade Handle - Biased Reverse Power**																		
	WT-2109-8	W-2109-8	1 3/8	M30	1	750-1650	1000-2250	880	4,300	12.9	327	21	9.5	2.2	56	1/2"	1/2"	100
	WTS-2109		1 3/8	M30	#5 Spl.	800-1800	1100-2450	880	4,300	13.1	333	21.5	9.8	2.2	56	1/2"	1/2"	100
	WT-2119-12		1 1/2	M36	1 1/2	1200-2600	1600-3500	820	3,300	14.3	362	29	13.1	2.3	59	1/2"	5/8"	105
	WTS-2119	WS-2119	1 1/2	M36	#5 Spl.	1200-2500	1600-3400	820	3,300	14.3	362	29	13.1	2.3	59	1/2"	5/8"	105

*6" Extended spindle
 **Breakaway torque capacity in reverse:
 2109 Series: 2500 ft.-lbs. (3400 Nm)
 2119 Series: 3500 ft.-lbs. (4700 Nm)

Standard Equipment:
 Operating instructions & service manual
 Dead handle bracket
 Dead Handle

Optional Equipment:
 Additional accessories: Pages 68-73

General:
 Tool performance rated at 90 psi (620kPa) air pressure.

Cleco®

Ergonomic Tool Balancers

Capacity:

0.5 - 20.5 kg

1.0 - 45 Lbs.

External tension adjustment

■ 360° Swivel

■ Retracting in-line cable

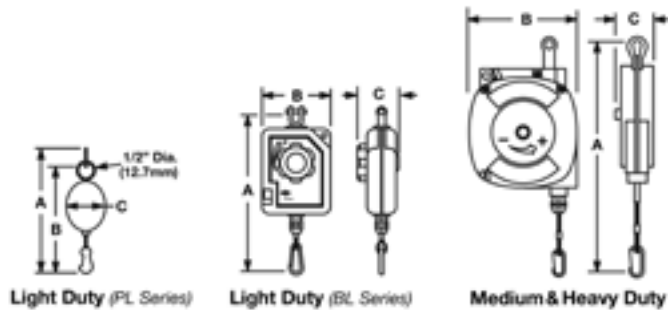

Model Number	Lock Feature	Capacity		"A"		"B"		"C"		Weight	
		lbs.	kg	in.	mm	in.	mm	in.	mm	lbs.	kg
Light Duty – 4.6 ft. (1.4m) Cable Travel											
PL-12A	–	12.0-1.0	5.5-0.5	6.8	171	5.1	130	2.3	58	–	–
Light Duty – 5.0 ft. (1.5m) Cable Travel											
200427	–	2.0-0	.9-0	10.9	277	4.4	112	1.6	41	1.3	0.6
200428	–	4.0-2.0	1.8-.9	10.9	277	4.4	112	1.6	41	1.3	0.6
200429	–	5.0-3.0	2.3-1.4	10.9	277	4.4	112	1.6	41	1.3	0.6
Light Duty – 5.2 ft. (1.6m) Cable Travel											
BL-2A	–	2.0-1.0	0.9-0.5	10.4	263	4.0	102	2.2	56	1.1	0.5
BL-4A	–	4.0-2.0	1.8-0.9	10.4	263	4.0	102	2.2	56	1.1	0.5
Light Duty – 6.7 ft. (2.0m) Cable Travel											
BL-6A	–	6.0-4.0	2.7-1.8	12.9	327	5.5	140	3.1	79	3.3	1.5
BLL-6A	Ratchet	6.0-4.0	2.7-1.8	12.9	327	5.5	140	3.1	79	3.3	1.5
BL-8A	–	8.0-6.0	3.6-2.7	12.9	327	5.5	140	3.1	79	3.3	1.5
BLL-8A	Ratchet	8.0-6.0	3.6-2.7	12.9	327	5.5	140	3.1	79	3.3	1.5
Medium Duty – 6.6ft. (2.0m) Cable Travel											
BM-13A	Automatic	13-9.0	5.9-4.1	13.8	350	6.9	175	4.5	114	9.0	4.1
BML-13A	Automatic/Ratchet	13-9.0	5.9-4.1	13.8	350	6.9	175	4.5	114	9.0	4.1
BM-18A	Automatic	18-13	8.2-5.9	13.8	350	6.9	175	4.5	114	9.0	4.1
Medium Duty – 6.0ft. (1.8m) Cable Travel											
BM-25A	Automatic	25-18	11.4-8.2	20.7	527	7.8	197	6.6	169	19	8.6
BM-35A	Automatic	35-25	15.9-11.4	20.7	527	7.8	197	6.6	169	19	8.6
BM-45A	Automatic	45-35	20.5-15.9	20.7	527	7.8	197	6.6	169	19	8.6

Air Hoses

Part Number	Hose I.D.		Fittings (NPT)		Length	
	in.	mm	in.	mm	ft.	m
A139856	3/16	4.7	1/8	1/8	6.0	1.8
45-1307	3/16	4.7	1/8	1/4	7.0	2.1
45-1408	1/4	6.4	1/4	1/4	8.0	2.4
45-1409	1/4	6.4	1/8	1/4	8.0	2.4
45-1508	5/16	7.9	1/4	1/4	8.0	2.4
45-1610	3/8	9.5	3/8	3/8	10	3.0
45-1810	1/2	12.7	3/8	1/2	10	3.0
45-1812	1/2	12.7	1/2	1/2	12	3.7
45-1825	1/2	12.7	1/2	1/2	25	7.6

General: 3/16" & 1/4" hoses have braided covers, all others have neoprene covers.

***Note:** 3/8"-24 is a straight thread



Activeswivel

Part No.	NPT in.	Air Flow		Max. Pressure		Weight	
		SCFM	m ³ /min	psig	bar	lbs.	kg
SW-102	1/4	25	7.1	150	10.4	0.20	0.09
SW-103	3/8	45	12.7	150	10.4	0.40	0.18
SW-104	1/2	65	18.4	150	10.4	0.80	0.36
SWR-102*	1/4	25	7.1	150	10.4	0.25	0.11

* NOTE: Equipped with built-in flow regulator.

Quick Disconnect Fittings

Fitting Type*	NPT in.	Nominal Size		
		1/4"	3/8"	1/2"
Coupler (male NPT)				
	1/8	45-0710	-	-
	1/4	45-0711	45-0713	-
	3/8	45-0712	-	-
	1/2	-	-	45-0717
Coupler (female NPT)				
	1/4	-	-	-
	3/8	45-0732	45-0734	45-0736
Nipple (male NPT)				
	1/8	45-0720	-	-
	1/4	-	45-0724	-
	3/8	45-0722	45-0725	45-0726
	1/2	-	-	45-0727
Nipple (female NPT)				
	1/4	-	45-0744	-
	3/8	45-0742	45-0745	45-0746
	1/2	-	-	45-0747
Nipple (with hose barbs)				
	1/4**	45-0748	-	-
	1/2**	-	-	45-0753

* NOTE: Nipples of one size will not fit couplers of another size.

** NOTE: Indicates inside diameter of hose.

NOTE: 1/4" nominal will pass 49 cfm free air @ 90 psi, but pressure drop exceeds 10 psi with air flow over 30 cfm.

3/8" nominal will pass 90 cfm free air @ 90 psi, but pressure drop exceeds 10 psi with air flow over 53 cfm.

1/2" nominal will pass 168 cfm free air @ 90 psi, but pressure drop exceeds 10 psi with air flow over 109 cfm.

Lubricants

Part Number	Size	Description	M.S.D.S. No.
Oils			
540397	1 qt. plastic	Air line oil	CPT-153
533485	1 gal. metal	Air line oil	CPT-153
536333	1 gal. metal	High film strength	CPT-154
45-0918	1 qt. plastic	Air line oil (<i>Dotco</i>)	CPT-155
45-0919	1 gal. metal	Air line oil (<i>Dotco</i>)	CPT-155
539317	1 qt. plastic	Hydraulic oil (<i>Pulse</i>)	CPT-157
Greases			
513156	18 oz. can	Teflon grease	CPT-145
45-0983	2 oz. tube	Dotco gear grease	CPT-147
45-0980	2 oz. tube	Dotco gear lube	CPT-148

NOTE: Under normal conditions of use, lubrication products sold separately for or used within these tools should not cause an exposure hazard. Refer to the Material Safety Data Sheet (M.S.D.S.) for Safety and Disposal information. M.S.D.S. sheets shown in the chart are available upon request from Cooper Power Tools.



Push Type Grease Gun

Part Number: 45-1982



Quality Fastener Tools

For more than half a century Apex has maintained the position of world leader in industrial fastening tools. Many power and insert bits, socket combinations and other drivers/adapters pioneered by Apex have today become industry standards, while Apex quality, service and selection give you unsurpassed value.

More Quality For Your Money

Apex quality starts with the selection of raw materials. Only carefully chosen, high grade tool steel is used to make Apex industrial fastener tools. Next, each tool is precision machined from solid bar stock to exacting standards of accuracy. You always get a snug, secure fit – a fit that is not possible from stamped tools.

Finally, each Apex fastener tool is tempered with our exclusive heat treating process. During this step the degree of hardness is determined based upon the application.

Fast Delivery

All Apex standard catalog items are available off-the-shelf for immediate delivery. If you need special assistance with your order, your Apex manufacturer's representative can handle any questions you may have.

Special Orders

Apex offers the broadest selection of screw driver and nut runner tools available, from bits, sockets and universal wrenches to extensions, adapters and nut setters. If you have a special application, contact your Apex representative. We may have what you need in stock, or can design and produce special fastener tools for almost any application.

Ordering Information

Apex products are distributed world-wide. For a catalog of the complete line of Apex quality fastener tools or to locate your nearest Apex distributor, visit our website at www.cooperpowertools.com or www.apex-tools.com.

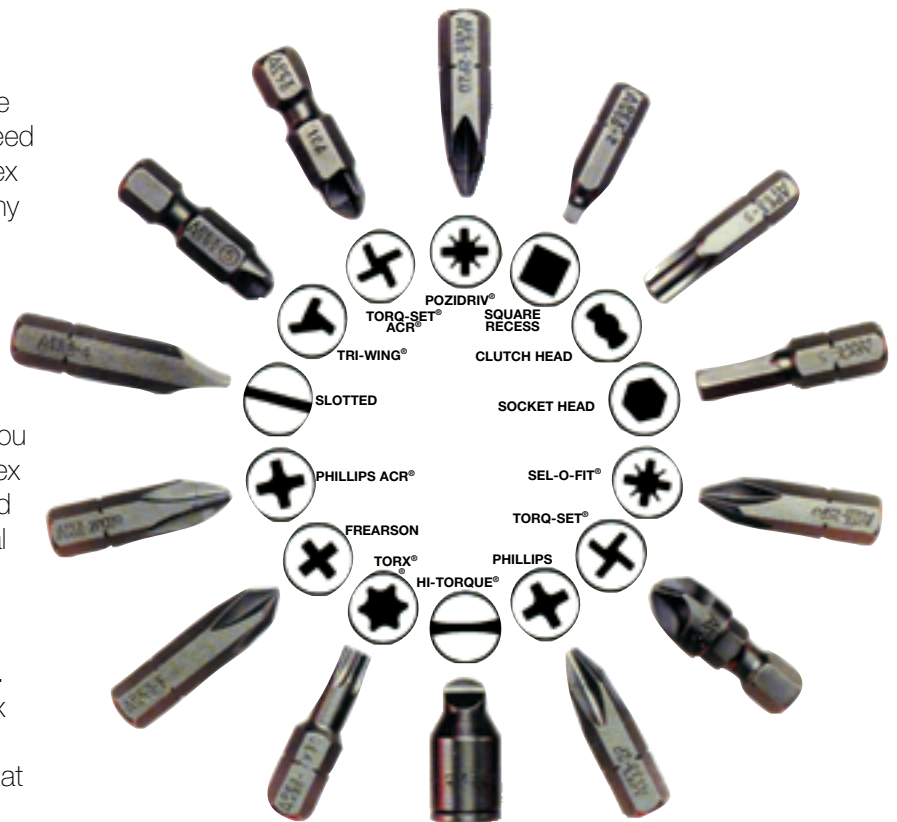

Registered Trade Marks: HI-TORQUE, Voi-Shan; TORX, Camcar Division of Textron; ACR, POZIDRIV, TORQ-SET and TRI-WING, Phillips International Co.; SUPADRIV, EIS (Fasteners) LTD.; SEL-O-FIT, FLIP-TIP, and Apex, Cooper Industries, Cooper Power Tools Division, Apex Operation.

Insert Bits

(1/4" hex for socket head cap screws and set screws)

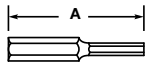

Part Number	Hex Size (in.)	"A"		Cap Screw	Set Screw
		in.	mm		
185-00	1/16	1.00	25.4	1	5.6
185-0	5/64	1.00	25.4	2.3	8
185-1	3/32	1.00	25.4	4.5	10
185-9	7/64	1.00	25.4	6	—
185-2	1/8	1.00	25.4	8	1/4
185-10	9/64	1.00	25.4	8	—
185-3	5/32	1.31	33.3	10	5/16
185-4	3/16	1.31	33.3	1/4	3/8
185-5	7/32	1.31	33.3	—	7/16
185-6	1/4	1.31	33.3	5/16	1/2
185-7	5/16	1.25	31.8	3/8	5/8
185-8	3/8	1.25	31.8	7/16, 1/2	3/4

Square Drive Adapter

(1/4" hex drive sockets) Use with Quick Change and Bit & Finder Models, except as noted.

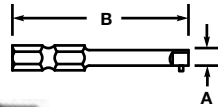

Part Number	"A" Sq. Drive	"B"		Bushing Number
		in.	mm	
EX250-2	1/4	2.00	50.8	—
EX250-3	1/4	3.00	76.2	847295*
EX250-4	1/4	4.00	101.6	—
EX250-6	1/4	6.00	152.4	—
EX370	3/8	1.63	41.3	—
EX370-3	3/8	3.00	76.2	847295*
EX500-2	1/2	2.00	50.8	—
EX500-3	1/2	3.00	76.2	—

*Note: Required for bit and finder models.

Hex Extensions

Part Number	Hex Drive (in.)	Type of Lock	Overall Length	
			in.	mm

Male Hex Drive with 1/2" Male Square

EX-501-3	7/16	Pin	3	76
EX-501-4	7/16	Pin	4	102
EX-501-6	7/16	Pin	6	152

Male Hex Drive with 3/8" Male Square

EX-371-3	7/16	Pin	3	76
EX-371-4	7/16	Pin	4	102
EX-371-6	7/16	Pin	6	152



Hex Drive Nutsetters

Part Number	Size (in.)	Overall Length (in.)	Socket Nose Diameter (in.)
-------------	------------	----------------------	----------------------------

7/16" 6 Point

6N-1416-3	1/2	3	13/16
6N-1416-4	1/2	4	13/16
6N-1418-3	9/16	3	7/8
6N-1418-4	9/16	4	7/8
6N-1420-3	5/8	3	1
6N-1420-6	5/8	6	1



Insert Bits

Used with Bit Holders
(all bits are 1.0" (25.4 mm) long)



Point Size	Part Number		Wood		Machine & Self-Tapping			
	Phillips	Pozi-Drive	Flat & Oval	Round	Flat, Oval & Pan	Fillister	Truss	Binding
0	446-0	446-1P2D	0.1	0.1	0.1	0.1	0.1	0.1
1	HPL-1	440-1PZD	2-4	2-4	2-4	2-4	2-4	2-4
2	HPI-2	440-2PZD	5-8	5-10	5-10	5-10	6-10	5-10
3	HPI-3	440-3PZD	10-16	12-16	12-16	12-5/16	12-16	12-1/4

6 Point Sockets

Part No.	Hex Opening	Overall Length	Nose End Diameter	Drive End Diameter	Opening Depth
----------	-------------	----------------	-------------------	--------------------	---------------

3/8" Square Drive Sockets, SAE

3112	3/8	1 1/4	19/32	3/4	1/4
3114	7/16	1 1/2	11/16	3/4	9/32
3116	7/16	1/2	1 1/2	13/16	11/32
3118	7/16	9/16	1-1/2	7/8	7/16

1/2" Square Drive Sockets, SAE

5112	3/8	1 1/2	5/8	15/16	1/4
5114	7/16	1 1/2	11/16	15/16	9/32
5116	1/2	1 1/2	13/16	15/16	11/32
5120	5/8	1 1/2	1	1	7/16
5122	11/16	1 1/2	1 1/8	1 1/8	7/16
5124	3/4	1 1/2	1 1/8	1 1/8	15/32

3/4" Square Drive Sockets, SAE

7128	7/8	2	1 1/2	1 1/2	9/16
7132	1	2	1 5/8	1 5/8	5/8
7136	1 1/8	2 1/8	1 3/4	1 3/4	3/4
7140	1 1/4	2 1/8	2	1 3/4	13/16
7144	1 3/8	2 1/8	2 1/8	2 1/8	13/16
7148	1 1/2	2 1/4	2 1/4	2 1/8	1

1" Square Drive Sockets, SAE

8132	1	2 1/8	1 5/8	2	13/16
8140	1 1/4	2 1/8	2 1/8	2 1/8	13/16
8144	1 3/8	2 1/8	2 1/8	2 1/8	13/16
8148	1 1/2	2 1/4	2 1/4	2 1/8	15/16
8156	1 3/4	2 3/8	2 5/8	2 5/8	11/16
8164	2	2 5/8	3	2 5/8	1 3/16

1 1/2" Square Drive Sockets, SAE

9156	1 3/4	2 7/8	2 7/8	3	1 1/8
9160	1 7/8	3	3 1/8	3	1 1/4
9164	2	3 1/8	3 1/4	3 1/4	1 3/8
9172	2 1/4	3 1/4	3 3/8	3 1/4	1 1/2

3/8" Square Drive Sockets, Metric

12mm13	12	38.1	19.1	19.1	7.2
14mm13	14	38.1	22.2	22.2	11.1
16mm13	16	38.1	23.8	23.8	11.1

1/2" Square Drive Sockets, Metric

16mm15	16	38.1	25.4	25.4	11.1
18mm15	18	38.1	28.6	28.6	11.1
20mm15	20	38.1	31.7	31.7	11.9
22mm15	22	38.1	33.3	33.3	14.3

5/8" Square Drive Sockets, Metric

24mm16	24	51	38.1	38.1	15.9
--------	----	----	------	------	------

3/4" Square Drive Sockets, Metric

28mm17	28	54	44.4	44.4	19.1
30mm17	30	54	47.6	44.4	19.1
32mm17	32	54	50.8	44.4	20.6
34mm17	34	54	54.0	54.0	20.6
36mm17	36	57	57.1	54.0	23.8

1" Square Drive Sockets, Metric

32mm18	32	54	54.0	54.0	20.6
34mm18	34	54	54.0	54.0	20.6
36mm18	36	57	57.1	54.0	23.9
38mm18	38	57	57.1	54.0	23.9
42mm18	42	60	63.5	54.0	23.9
46mm18	46	64	69.8	66.7	26.9



APEX® μ -Guard™

Quality Anti-Mar Fastener Tools Begin With Quality Fastener Tools.

Apex μ -Guard™ provides a protective barrier between genuine Apex fastener tools and your finely finished workpiece. The free-spinning patent-pending design provides maximum protection for polished and highly sensitive surfaces.

Apex μ -Guard™ covering is made of a thermo plastic urethane (TPU elastomer) which cushions against costly incidental side impacts. It offers the lowest coefficient of friction for maximum tool efficiency. It is also non-removable for tamper resistance.

With Apex μ -Guard™ you get the proven Apex fastener tool fit and performance plus the best protection available against marring and in-system damage.

μ -Guard™ is your guard against the potential hazards caused by rotational friction.



If it doesn't say Apex on the outside, how can you be sure of what's on the inside?

Prevents Side Impact Damage



Free-Spinning Design



Virtually Damage Free



μ-Guard Sockets

(Includes socket and cover)



Part Number	Socket	Drive End			Socket Length	Fastener End			Assembly Features
		Size	Type	Sex		Size	Type	Sex	
UGS-AB710	10MM21	1/4	Square	F	standard	10 mm	Hex	F	FS
UGS-AB710-01	M-10MM21	1/4	Square	F	standard	10 mm	Hex	F	FS, M
UGS-AB710-02	MB-10MM21	1/4	Square	F	standard	10 mm	Hex	F	FS, M, B
UGS-BA610	10MM13	3/8	Square	F	standard	10 mm	Hex	F	FS
UGS-BA610-01	M-10MM13	3/8	Square	F	standard	10 mm	Hex	F	FS, M
UGS-BB710	10MM23	3/8	Square	F	long	10 mm	Hex	F	FS
UGS-BB710-01	M-10MM23	3/8	Square	F	long	10 mm	Hex	F	FS, M
UGS-BB710-02	MB-10MM23	3/8	Square	F	long	10 mm	Hex	F	FS, M, B
UGS-BB713	13MM23	3/8	Square	F	long	13 mm	Hex	F	FS
UGS-BB713-01	M-13MM23	3/8	Square	F	long	13 mm	Hex	F	FS, M
UGS-BB713-02	MB-13MM23	3/8	Square	F	long	13 mm	Hex	F	FS, M, B
UGS-CB713	13MM25	1/2	Square	F	long	13 mm	Hex	F	FS
UGS-CB713-03	SF-13MM25	1/2	Square	F	long	13 mm	Hex	F	FS, SF
UGS-CB715	15MM25	1/2	Square	F	long	15 mm	Hex	F	FS
UGS-CB715-03	SF-15MM25	1/2	Square	F	long	15 mm	Hex	F	FS, SF
UGS-CB718	18MM25	1/2	Square	F	long	18 mm	Hex	F	FS
UGS-CB718-03	SF-18MM25	1/2	Square	F	long	18 mm	Hex	F	FS, SF

If your tool is not shown in the table of representative products above, please contact your Apex representative.

μ-Guard Extensions

(Includes extension and cover)



Part Number	Extension	Drive End			Extension Length	Socket End			Assembly Features*
		Size	Type	Sex		Size	Type	Sex	
UGE-A2A	EX-250-2	1/4	Hex	M	2	1/4	Square	M	FS
UGE-A4A	EX-250-4	1/4	Hex	M	4	1/4	Square	M	FS
UGE-A6A	EX-250-6	1/4	Hex	M	6	1/4	Square	M	FS
UGE-B2A	EX-370-2	1/4	Hex	M	2	3/8	Square	M	FS
UGE-B4A	EX-370-4	1/4	Hex	M	4	3/8	Square	M	FS
UGE-B6A	EX-370-6	1/4	Hex	M	6	3/8	Square	M	FS
UGE-B3C	EX-376-3	3/8	Square	F	3	3/8	Square	M	FS
UGE-B6C	EX-376-6	3/8	Square	F	6	3/8	Square	M	FS
UGE-B12C	EX-376-12	3/8	Square	F	12	3/8	Square	M	FS
UGE-C4C	EX-508-4	1/2	Square	F	4	1/2	Square	M	FS
UGE-C8C	EX-508-8	1/2	Square	F	8	1/2	Square	M	FS
UGE-C12C	EX-508-12	1/2	Square	F	12	1/2	Square	M	FS

If your tool is not shown in the table of representative products above, please contact your Apex representative.

μ-Guard Bit Holders

(Includes bit holder and cover)



Part Number	Bit Holder	Drive End			Socket Length	Fastener End			Assembly Features
		Size	Type	Sex		Size	Type	Sex	
UGH-1NAA	M-490	1/4	Hex	M	2 31/32	1/4	Hex	F	FS, M, ET
UGH-1AAA	M-490-2	1/4	Hex	M	2	1/4	Hex	F	FS, M, ET
UGH-2NBG	838	3/8	Square	F	1 1/2	1/4	Hex	F	FS, ET
UGH-1NBG	M-838	3/8	Square	F	2 5/8	1/4	Hex	F	FS, M, ET
UGH-2NBC	835	3/8	Square	F	1 1/2	5/16	Hex	F	FS, ET
UGH-1NBC	M-835	3/8	Square	F	2 3/4	5/16	Hex	F	FS, M, ET
UGH-2NBD	855	1/2	Square	F	1 1/2	5/16	Hex	F	FS, ET
UGH-1NBD	M-855	1/2	Square	F	2 3/4	5/16	Hex	F	FS, M, ET
UGH-2NCK	QR-308	3/8	Square	F	1 3/4	1/4	Hex	F	FS, QR
UGH-2NCF	QR-508	1/2	Square	F	2 1/8	1/4	Hex	F	FS, QR
UGH-2NCJ	QR-314	3/8	Square	F	2	7/16	Hex	F	FS, QR
UGH-2NCL	QR-514	1/2	Square	F	2 1/8	7/16	Hex	F	FS, QR

If your tool is not shown in the table of representative products above, please contact your Apex representative.

*Features Abbreviations

- FS** Free Spinning Tool is able to rotate independently of Cover
- M** Magnetic Tool includes magnet to hold the position of the fastener during fastening operation
- B** Bolt Clearance Tool is spring-loaded to allow bolt or nut to retract into the socket body
- SF** Surface Drive Tool has radiused corners to allow easier alignment and engagement of fastener
- ET** Exposed Tip Cover extends beyond end of Bit Holder to shield the majority of a standard 1 inch long Insert Bit.

- QR** Quick Release Tool has tension feature to allow quick & easy change between bits
- Cover will not extend beyond end of Bit Holder

Notes: Reported lengths are based on uncovered tool length only for reference. Cover may extend beyond end of tool by 2 mm unless otherwise noted.

Conversion Tables

Millimeter – Decimal – Fraction

mm	Dec.	in.	mm	Dec.	in.	mm	Dec.	in.	mm	Dec.	in.	mm	Dec.	in.
0.100	.0039		5.159	.2031	13/64	10.300	.4055		15.400	.6063		20.400	.8031	
0.200	.0079		5.200	.2047		10.319	.4063	13/32	15.478	.6094	39/64	20.500	.8071	
0.300	.0118		5.300	.2087		10.400	.4094		15.500	.6102		20.600	.8110	
0.397	.0156	1/64	5.400	.2126		10.500	.4134		15.600	.6142		20.638	.8125	13/16
0.400	.0157		5.500	.2165		10.600	.4173		15.700	.6181		20.700	.8150	
0.500	.0197		5.556	.2188	7/32	10.700	.4219		15.800	.6220		20.800	.8189	
0.600	.0236		5.600	.2205		10.716	.4219	27/64	15.875	.6250	5/8	20.900	.8228	
0.700	.0276		5.700	.2244		10.800	.4252		15.900	.6250		21.000	.8268	
0.794	.0313	1/32	5.800	.2283		10.900	.4291		16.000	.6299		21.034	.8182	53/64
0.800	.0315		5.900	.2323		11.000	.4331		16.100	.6339		21.100	.8307	
0.900	.0354		5.953	.2344	15/64	11.100	.4370		16.200	.6378		21.200	.8307	
1.000	.0394		6.000	.2362		11.113	.4375	7/16	16.272	.6406	41/64	21.200	.8346	
1.100	.0433		6.100	.2402		11.200	.4409		16.300	.6417		21.300	.8386	
1.191	.0469	3/64	6.200	.2441		11.300	.4449		16.400	.6457		21.400	.8425	
1.200	.0472		6.300	.2480		11.400	.4488		16.500	.6496		21.431	.8438	27/32
1.300	.0512		6.350	.2500	1/4	11.500	.4528		16.600	.6535		21.500	.8465	
1.400	.0551		6.400	.2520		11.509	.4531	29/64	16.669	.6563	21/32	21.600	.8504	
1.500	.0591		6.500	.2559		11.600	.4567		16.700	.6575		21.700	.8543	
1.588	.0625	1/16	6.600	.2598		11.700	.4606		16.800	.6614		21.800	.8583	
1.600	.0630		6.700	.2638		11.800	.4646		16.900	.6654		21.828	.8594	55/94
1.700	.0669		6.747	.2656	17/64	11.900	.4685		17.000	.6693		21.900	.8622	
1.800	.0709		6.800	.2677		11.906	.4688	15/32	17.066	.6719	43/64	22.000	.8661	
1.900	.0748		6.900	.2717		12.000	.4724		17.100	.6732		22.100	.8701	
1.984	.0781	5/64	7.000	.2756		12.100	.4764		17.200	.6772		22.200	.8740	
2.000	.0878		7.100	.2795		12.200	.4803		17.300	.6811		22.225	.8750	7/8
2.100	.0827		7.144	.2813	9/32	12.300	.4843		17.400	.6850		22.300	.8780	
2.200	.0866		7.200	.2835		12.303	.4844	31/64	17.463	.6875	11/16	22.400	.8819	
2.300	.0906		7.300	.2874		12.400	.4882		17.500	.6890		22.500	.8858	
2.381	.0938	3/32	7.400	.2913		12.500	.4921		17.600	.6929		22.600	.8898	
2.400	.0945		7.500	.2953		12.600	.4961		17.700	.6968		22.622	.8906	57/64
2.500	.0984		7.541	.2969	19/64	12.700	.5000	1/2	17.800	.7008		22.700	.8937	
2.600	.1024		7.600	.2992		12.800	.5039		17.859	.7031	45/64	22.800	.8976	
2.700	.1063		7.700	.3031		12.900	.5079		17.900	.7047		22.900	.9016	
2.778	.1094	7/64	7.800	.3071		13.000	.5118		18.000	.7087		23.000	.9055	
2.800	.1102		7.900	.3110		13.097	.5156	33/64	18.100	.7126		23.019	.9063	29/32
2.900	.1142		7.938	.3125	5/16	13.100	.5157		18.200	.7165		23.100	.9094	
3.000	.1181		8.000	.3150		13.200	.5197		18.256	.7188	23/32	23.200	.9134	
3.100	.1220		8.100	.3189		13.300	.5236		18.300	.7205		23.300	.9173	
3.175	.1250	1/8	8.200	.3228		13.400	.5276		18.400	.7244		23.400	.9213	
3.200	.1260		8.300	.3268		13.494	.5313	17/32	18.500	.7283		23.416	.9219	59/64
3.300	.1299		8.334	.3281	21/64	13.500	.5315		18.600	.7323		23.500	.9252	
3.400	.1339		8.400	.3307		13.600	.5354		18.653	.7344	47/64	23.600	.9291	
3.500	.1378		8.500	.3346		13.700	.5394		18.700	.7362		23.700	.9331	
3.572	.1406	9/64	8.600	.3386		13.800	.5433		18.800	.7402		23.800	.9370	
3.600	.1417		8.700	.3425		13.891	.5469	35/64	18.900	.7441		23.900	.9409	
3.700	.1457		8.731	.3438	11/32	13.900	.5472		19.000	.7480		24.000	.9449	
3.800	.1496		8.800	.3465		14.000	.5512		19.050	.7500	3/4	24.100	.9488	
3.900	.1535		8.900	.3504		14.100	.5551		19.100	.7520		24.200	.9528	
3.969	.1563	5/32	9.000	.3543		14.200	.5591		19.200	.7559		24.209	.9531	61/64
4.000	.1575		9.100	.3583		14.288	.5625	9/16	19.300	.7598		24.300	.9567	
4.100	.1624		9.128	.3594	23/64	14.300	.5630		19.400	.7638		24.400	.9606	
4.200	.1654		9.200	.3622		14.400	.5669		19.447	.7656	49/64	24.500	.9646	
4.300	.1693		9.300	.3661		14.500	.5709		19.500	.7677		24.600	.9685	
4.366	.1719	11/64	9.400	.3701		14.600	.5748		19.600	.7717		24.606	.9688	31/32
4.400	.732		9.500	.3740		14.684	.5781	37/64	19.700	.7756		24.700	.9724	
4.500	.1772		9.525	.3750	3/8	14.700	.5787		19.800	.7795		24.800	.9764	
4.600	.1811		9.700	.3819		14.800	.5827		19.844	.7813	25/32	24.900	.9803	
4.700	.1850		9.800	.3858		14.900	.5866		19.900	.7835		25.000	.9843	
4.763	.1875	3/16	9.900	.3898		15.000	.5906		20.000	.7874		25.003	.9844	63/64
4.800	.1890		9.922	.3902	25/64	15.081	.5938	19/32	20.100	.7913		25.100	.9882	
4.900	.1929		10.000	.3937		15.100	.5945		20.200	.7953		25.200	.9921	
5.000	.1969		10.100	.3976		15.200	.5984		20.241	.7969	51/64	25.300	.9961	
5.100	.2008		10.200	.4016		15.300	.6024		20.300	.7992		25.400	1.000	1

Conversion Tables

Torque – Air Pressure – Miscellaneous

Torque Conversion Factors		
To Convert	Into	Multiply By
Inch Pounds	Foot Pounds	0.0835
Inch Pounds	Newton meters	0.1130
Inch Pounds	Kg-meters	0.0115
Inch Pounds	Kg-Cm	1.1519
Foot Pounds	Inch Pounds	12.000
Foot Pounds	Newton meters	1.3560
Foot Pounds	Kg-meters	0.1382
Foot Pounds	Kg-Cm	13.8240
Newton Meters	Inch Pounds	8.8440
Newton Meters	Foot Pounds	0.7370
Newton Meters	Kg-meters	0.1020
Newton Meters	Kg-Cm	10.2000
Kg meters	Inch Pounds	86.8100
Kg meters	Foot Pounds	7.2340
Kg meters	Newton-meters	9.8040
Kg Cm	Inch Pounds	0.8681
Kg Cm	Foot Pounds	0.0723
Kg Cm	Newton-meters	0.0980

Torque Conversion – In. Lbs. (Nm)					
In. Lbs.	Nm	In. Lbs.	Nm	In. Lbs.	Nm
5	0.6	50	5.7	140	15.8
10	1.1	60	6.8	150	17.0
15	1.7	70	7.9	160	18.1
20	2.3	80	9.0	170	19.2
25	2.8	90	10.2	180	20.3
30	3.4	100	11.3	190	21.5
35	4.0	110	12.4	200	22.6
40	4.5	120	13.6		
45	5.1	130	14.7		

Torque Conversion – Ft. Lbs. (Nm)							
Ft. Lbs.	Nm	Ft. Lbs.	Nm	Ft. Lbs.	Nm	Ft. Lbs.	Nm
1	1.36	33	44.8	65	88.1	97	131.5
2	2.7	34	46.1	66	90.0	98	133.0
3	4.1	35	47.5	67	90.9	99	134.2
4	5.4	36	48.8	68	92.2	100	135.6
5	6.8	37	50.2	69	93.6	110	149.2
6	8.1	38	52.0	70	94.9	115	156.0
7	9.5	39	52.9	71	96.3	120	163.0
8	10.9	40	54.2	72	97.6	125	170.0
9	12.2	41	55.6	73	99.0	130	176.3
10	13.6	42	57.0	74	100.3	135	183.1
11	14.9	43	58.3	75	102.0	140	190.0
12	16.3	44	60.0	76	103.1	145	197.0
13	17.6	45	61.0	77	104.4	150	203.4
14	19.0	46	62.4	78	105.8	155	210.2
15	20.3	47	63.7	79	107.1	160	217.0
16	21.7	48	65.1	80	108.5	165	224.0
17	23.1	49	66.4	81	110.0	170	231.0
18	24.4	50	67.8	82	111.2	175	237.3
19	25.8	51	69.2	83	112.6	180	244.1
20	27.1	52	70.5	84	114.0	185	251.0
21	28.5	53	71.9	85	115.3	190	258.0
22	29.8	54	73.2	86	117.0	195	264.4
23	31.2	55	74.6	87	118.0	200	271.2
24	32.5	56	75.9	88	119.3	225	305.1
25	33.9	57	77.3	89	121.0	250	339.0
26	35.3	58	78.7	90	122.0	275	373.0
27	36.6	59	80.0	91	123.4	300	407.0
28	38.0	60	81.4	92	125.0	350	475.0
29	39.3	61	82.7	93	126.1	400	542.4
30	40.7	62	84.1	94	127.5		
31	42.0	63	85.4	95	129.0		
32	43.4	64	86.8	96	130.2		

Inch Bolt Torque Table

SAE J429 and ASME 574

Steel Grade	SAE 5		SAE 8		Socket Head Cap Screws	
	Dry	Lubed	Dry	Lubed	Dry	Lubed
1/4-20	(101)	(76)	(143)	(107)	(168)	(120)
1/4-28	(116)	(87)	(147)	(123)	(192)	(144)
5/16-18	(209)	(157)	(295)	(221)	(348)	(264)
5/16-24	(231)	(174)	(327)	(245)	(384)	(288)
3/8-16	(372)	(276)	44	33	51	38
3/8-24	(420)	(312)	49	37	58	43
7/16-14	49	37	70	52	81	61
7/16-20	55	41	78	58	91	68
1/2-13	75	57	106	80	124	93
1/2-20	85	64	120	90	140	105
5/8-11	150	113	212	159	238	179
5/8-18	170	127	240	180	270	202
3/4-10	267	200	376	282	423	317
3/4-16	297	223	420	315	472	354
7/8-9	429	322	606	455	682	511
7/8-14	474	355	669	502	752	564
1-8	644	483	909	681	1022	767
1-12	722	542	1020	765	1147	860

Metric Bolt Torque Table

ISO 889

Property Class	8.8		10.9		12.9 Socket Head Cap Screw	
	Torque in Newton Meter - Nm					
Nom Size x Pitch	Dry	Lubed	Dry	Lubed	Dry	Lubed
M5 x 0.80	6.1	4.6	8.8	6.7	10.3	7.7
M6 x 1.00	10.4	7.8	15	11.2	17.6	13.1
M7 x 1.00	17.6	13.1	25.1	18.9	29.4	22
M8 x 1.25	25.4	19.1	37.6	27.3	42.6	32.1
M10 x 1.50	50	38	72	54	84	64
M12 x 1.75	88	66	126	94	146	110
M14 x 2.00	141	106	201	150	235	176
M16 x 2.00	218	164	312	233	365	274
M18 x 2.50	301	226	431	323	504	378
M20 x 2.50	426	319	609	457	712	534
M22 x 2.50	580	435	831	624	971	728
M24 x 3.00	736	552	1052	789	1231	923
M27 x 3.00	1079	809	1544	1158	1805	1353
M30 x 3.50	1463	1097	2092	1570	2446	1834
M33 x 3.50	1990	1493	2849	2137	3328	2497
M36 x 4.00	2557	1918	3659	2744	4276	3208

Lubed means cleaned dry bolts lubricated with a standard medium viscosity machine oil. Lubricate all contact areas of the bolts and washers. Lubricating the bolts is the suggested method.

Miscellaneous Conversion Factors			Air Pressure Conversion		
To Convert	Into	Multiply By	PSI	kPa*	Bar**
Inches	Millimeters	25.4000	85	586	5.9
Millimeters	Inches	0.0394	90	620	6.2
Pounds	Kilograms	0.4536	95	655	6.6
Kilograms	Pounds	2.2050	100	690	6.9
psi	bar	0.069	125	860	8.6
bar	psi	14.5			

*Preferred: Approximate to the nearest 5 kPa.
**Approximate to the nearest 0.5 Bar.

The Total Solution

The total solution from Cooper Power Tools includes not only a complete line of quality industrial tools and accessories but also a professional engineering and product support staff to help customize each tool to specific application requirements. All are as close as a telephone or e-mail.

Cooper Power Tools maintains company-owned Service Centers in strategic locations throughout the world, staffed with professional tool repair technicians who use genuine Cooper Power Tools parts and who are outfitted with the very latest in testing, calibration and inspection equipment. Each tool that is returned to a customer from one of our Service Centers carries with it a warranty that is Cooper Power Tools' assurance that it will perform just like it did when it was purchased new.

Our support personnel are fully capable of helping to diagnose problems and promptly recommend solutions.



Our complete line of tools are carefully designed and built from the finest materials available in order to provide years of trouble free service. But, as with any piece of equipment, service problems can occur. All tools are designed to be easy to service ... that is, of course, with properly trained personnel.

To facilitate quick repairs, and limit downtime

TRAINING

... Cooper Power Tools conducts training seminars covering all aspects of every tool we make.

Introductory training seminars are designed to fully acquaint students with the entire line of tools and their fundamental operation. Advanced training seminars, which are often tailored to individual needs, are designed to hone the skills of the experienced student. Hands-on experience, with an emphasis on troubleshooting and repairing, are the focus of this training.

Service literature, product information, brand catalogs and FAQs are also available around the clock on the web. Just access www.cooperpowertools.com for the latest information available.





Sales & Service Centers

Note: All locations may not service all products. Please contact the nearest Sales & Service Center for the appropriate facility to handle your service requirements.

Dallas, TX

**Cooper Power Tools
Sales & Service Center**
1470 Post & Paddock
Grand Prairie, TX 75050
Tel: (972) 641-9563
Fax: (972) 641-9674

Detroit, MI

**Cooper Power Tools
Sales & Service Center**
4121 North Atlantic Blvd.
Auburn Hills, MI 48326
Tel: (248) 391-3700
Fax: (248) 391-6295

Houston, TX

**Cooper Power Tools
Sales & Service Center**
6550 West Sam Houston
Parkway North, Suite 200
Houston, TX 77041
Tel: (713) 849-2364
Fax: (713) 849-2047

Seattle, WA

**Cooper Power Tools
Sales & Service Center**
2865 152nd Ave N.E.
Redmond, WA 98052
Tel: (425) 497-0476
Fax: (425) 497-0496

Lexington, SC

Cooper Power Tools
670 Industrial Drive
Lexington, SC 29072
Tel: (800) 845-5629
Tel: (803) 951-7544
Fax: (803) 358-7681

York, PA

**Cooper Power Tools
Sales & Service Center**
York Service Center
3990 E. Market Street
York, PA 17402
Tel: (717) 755-2933
Fax: (717) 757-5063

Brazil

Cooper Tools Industrial Ltda.
Av. Liberdade, 4055
Zona Industrial - Iporanga
18087-170 Sorocaba, SP Brazil
Tel: (011) 55 15 238 3929
Fax: (011) 55 15 228 3260

Canada

**Cooper Power Tools
Sales & Service Center**
5925 McLaughlin Road
Mississauga, Ont. L5R 1B8
Canada
Tel: (905) 501-4785
Fax: (905) 501-4786

China

Cooper (China) Co., Ltd.
955 Sheng Li Road,
Heqing Pudong, Shanghai
China 201201
Tel: +86-21-28994176
Fax: + 86-21-51118446

France

**Cooper Power Tools SAS
Recoules Operation**
Zone Industrielle
BP 28
Avenue Maurice Chevalier
77831 Ozoir-la-Ferrière Cedex
France
Tel: (011) 33 1 64 43 22 00
Fax: (011) 33 1 64 40 17 17

Germany

**Cooper Power Tools
GmbH & Co. OHG**
Postfach 30
D-73461 Westhausen
Tel: +49 (0) 73 63/ 81-0
Fax: +49 (0) 73 63/ 81-222

Mexico

**Cooper Power Tools
de México S.A. de C.V.**
Libramiento La Joya No. 1
Bodega No. 2
Esq. Politécnico, Barrio San José
Cuautitlán, Edo de México C.P. 54870
Phone: (011) 525 5899 9510
Fax: (011) 525 5870 5012

Cooper Power Tools Is On The Web!

Cooper Power Tools provides a complete resource for power tools on-line. Our website www.cooperpowertools.com offers product information, service literature, brand catalogs, press releases and more. A dominant source of information, the Cooper Power Tools website is your source for application solutions on-line.



Making your job easier is our goal!

You can access service literature anytime. Choose a category such as Assembly Tools or Material Removal Tools from the main menu and then click on the brand you're looking for. You'll be on your way to any current service literature you need, whether it's Cleco, Apex, Master Power, or any of our power tool brands.



Up-to-date product catalogs are also available online providing

you with current information on our broad product line. Even Material Safety Data Sheets (M.S.D.S.) for Safety and Disposal Information are available on our website.



It's simple!

Our *Customer Care* section provides you with information such as answers to frequently asked questions or contact phone numbers and addresses for your area of the country. You can browse through the *What's New* information to learn how Cooper Power Tools continues to be your source for solutions.



For even faster searches, you can go direct to a brand site by simply entering the brand name. Entering www.dotco-tools.com takes you directly to the Dotco brand site.

What is the future of www.cooperpowertools.com? A dynamic site continuing to focus on your need for up-to-date information on the latest Cooper Power Tools' offerings that you can access anytime you need... twenty-four hours a day, seven days a week!

One of the broadest range of tools in the world is at your fingertips!

Cooper Power Tools covers a wide range of industrial markets, including aerospace, automotive, foundries, furniture, general industry, metal fabrication, petroleum, power generation, shipbuilding, and transportation. These markets have been served by Cooper Power Tools' brands for many decades, by offering our customers solutions and products that meet their demanding productivity requirements.

To receive a product catalog quickly, just go to www.cooperpowertoolscatalogs.com. Select the literature or software you want. Then complete the "Contact Information" form, hit "Submit Request" and your order will be processed immediately. Materials normally arrive within 48 hours.



Apex Fastener Tools

A comprehensive line of industrial quality bits, finders, sockets and extensions.
(Catalog # TC-100)
www.apex-tools.com



Dotco/Cleco Material Removal Tools

A full line of pneumatic material removal tools including drills, sanders, and grinders.
(Catalog # SP-102)
www.dotco-tools.com



Gardner-Denver Air Hoists

A broad line of quality pneumatic hoists for industrial applications.
(Catalog # SP-103)
www.gardnerdenvertools.com



Apex Universal Joints

Industrial quality universal joints that can be custom designed for most any application.
(Catalog # SP-1400)
www.apexuniversal.com



Buckeye • Dotco • Gardner-Denver Power Motors

A comprehensive line of industrial pneumatic motors for a multitude of applications.
(Catalog # SP-104)
www.buckeye-tools.com



Master Power Industrial Air Tools

A complete line of industrial pneumatic tools for assembly and material removal applications.
(Catalog # SP-904)
www.masterpowertools.com



Cleco Pneumatic Assembly Tools

A full line of industrial pneumatic assembly tools from screwdrivers to nutrunners to impacts.
(Catalog # SP-1000)
www.clecotools.com



Buckeye Fixtured Drills

An extensive line of industrial pneumatic fixtured drills.
(Catalog # SP-105)
www.buckeye-tools.com



Utica Torque Products

A full line of torque measuring products including torque screwdrivers, torque wrenches and analyzers.
(Catalog # SP-301)
www.uticatools.com



Cleco D.C. Electric Assembly Tools

A complete line of industrial D.C. electric assembly tools and controllers.
(Catalog # SP-105)
www.clecotools.com



Airetool Tube Cleaners & Expanders

A complete line of industrial tube cleaners, expanders and installation tools.
(Catalog # SP-1100)
www.airetools.com

Sales & Service Centers

Note: All locations may not service all products. Please contact the nearest Sales & Service Center for the appropriate facility to handle your service requirements.

Dallas, TX
Cooper Power Tools
Sales & Service Center
1470 Post & Paddock
Grand Prairie, TX 75050
Tel: (972) 641-9563
Fax: (972) 641-9674

Detroit, MI
Cooper Power Tools
Sales & Service Center
4121 North Atlantic Blvd.
Auburn Hills, MI 48326
Tel: (248) 391-3700
Fax: (248) 391-6295

Houston, TX
Cooper Power Tools
Sales & Service Center
6550 West Sam Houston
Parkway North, Suite 200
Houston, TX 77041
Tel: (713) 849-2364
Fax: (713) 849-2047

Lexington, SC
Cooper Power Tools
670 Industrial Drive
Lexington, SC 29072
Tel: (800) 845-5629
Tel: (803) 359-1200
Fax: (803) 358-7681

Seattle, WA
Cooper Power Tools
Sales & Service Center
2865 152nd Ave N.E.
Redmond, WA 98052
Tel: (425) 497-0476
Fax: (425) 497-0496

York, PA
Cooper Power Tools
Sales & Service Center
3990 East Market Street
York, PA 17402
Tel: (717) 755-2933
Fax: (717) 757-5063

Canada
Cooper Power Tools
Sales & Service Center
5925 McLaughlin Road
Mississauga, Ont. L5R 1B8
Canada
Tel: (905) 501-4785
Fax: (905) 501-4786

Cooper Power Tools
P.O. Box 1410
Lexington, SC 29071-1410
USA
Phone: 800-845-5629
803-359-1200
Fax: 803-359-0822

Cooper Power Tools
4121 North Atlantic Blvd.
Auburn Hills, MI 48326
USA
Phone: (248) 391-3700
Fax: (248) 391-7824

Cooper Power Tools
5925 McLaughlin Road
Mississauga, Ontario
Canada L5R 1B8
Phone: (905) 501-4785
Fax: (905) 501-4786

Cooper Power Tools
de México S.A. de C.V.
Libramiento La Joya No. 1
Bodega No. 2
Esq. Politécnico
Barrio San José
Cuautitlán, Edo de México
C.P. 54870
Phone: +52-55-5899-9510
Fax: +52-55-5870-5012

Cooper Tools Industrial Ltda.
Av. Liberdade, 4055
Zona Industrial - Iporanga
18087-170 Sorocaba, SP
Brazil
Tel: +55-15-3238-3929
Fax: +55-15-228-3260

Cooper Power Tools SAS
Zone industrielle - B.P. 28
77831 Ozoir-la-Ferrière Cedex
France
Téléphone: +33-1-6443-2200
Téléfax: +33-1-6440-1717

Cooper Power Tools
GmbH & Co. OHG
Postfach 30
D-73461 Westhausen
Germany
Phone: +49 (0) 73 63/ 81-0
Fax: +49 (0) 73 63/ 81-222
E-Mail:
sales-de@cooperindustries.com

Cooper Tools Hungária Kft.
Berkenyefa sor 7
H-9027 Győr
Hungary
Tel: +36-96-505 300
Fax: +36-96-505 301

Cooper (China) Co., Ltd.
955 Sheng Li Road,
Heqing Pudong, Shanghai
China 201201
Tel: +86-21-28994176
+86-21-28994177
Fax: + 86-21-51118446

www.cooperpowertools.com

Cooper Industries, Ltd.
600 Travis, Ste. 5800
Houston, TX 77002-1001
P: 713-209-8400
www.cooperindustries.com